



REVISION

LET	DESCRIPTION	DATE	APPD
A	BY REV: ON KMA62 & KMA55 WIRES; S-1635-1 WAS S-1367-1-8	DGP 10-16-69	JWH DGP

K	MATERIAL	LG	TERMINALS	SERIALS
K-MA66	20		S-1635-1	SOLDER
K-MA65	20		S-1635-1	S-1636-1
K-MA64	20		SOLDER	S-1634-1
K-MA63	20		SOLDER	SOLDER
K-MA62	20		S-1635-1	SOLDER
K-MA61	20		S-1635-1	S-1636-1
K-MA60	20		SOLDER	S-1636-1
K-MA59	20		SOLDER	SOLDER
K-MA58	20		S-1367-1-4	S-1367-1-8
K-MA57	20		S-1636-1	S-1367-1-4
K-MA56	20		SOLDER	S-1635-1
K-MA55	20		S-1633-1	SOLDER
K-MA54	20		S-1367-1-4	S-1367-1-4
K-MA53	20		S-1636-1	S-1367-1-4
K-MA52	20		SOLDER	S-1635-1
K-MA51	20		S-341-2	SOLDER
K-MA50	20		SOLDER	S-341-2
K-MA49	20		S-1635-1	SOLDER
K-MA48	20		S-1367-1-4	S-1636-1
K-MA47	20		WE	EM35 S-1367-1-4
K-MA46	20		S-1635-1	SOLDER
K-MA45	20		S-1636-1	S-1367-1-4
K-MA44	20		S-1367-1-4	S-1636-1
K-MA43	20		SOLDER	S-1635-1
K-MA42	20		S-1367-1-4	S-1367-1-8
K-MA41	20		S-1636-1	S-1367-1-4
K-MA40	20		SOLDER	S-1635-1
K-MA39	20		S-341-2	SOLDER
K-MA38	20		SOLDER	S-341-2
K-MA37	20		S-1635-1	SOLDER
K-MA36	20		S-1367-1-4	S-1636-1
K-MA35	20		S-1635-2	S-1367-1-4
K-MA34	20		S-1367-1-8	S-1636-1
WIRE	NO GA			

WIRE TABLE

CONTRACT NO		COMMERCIAL AIRCRAFT DIV. 3800 E PAWNEE WICHITA, KANSAS	
DESIGN	NAME	DATE	TITLE
ZONAKER	ZONAKER	5-3-69	WIRING DIAGRAM --
GROUP	H. WISE	5-17-68	COWL FLAPS-FRONT & REAR
DRAWN	YOUNGERS	2-1-68	
CHECK	LAURIE	2-6-68	
STRESS	D. MCCOSH	2-15-68	
PROJ	J. SATTLER	2-22-68	
APPD			
OTHER			
SIZE	CODE IDENT	DWG NO	
C	71379	1570000	
SCALE	NONE	337	PAGE: 16.4.0

(DUPLICATE COPY)

INACTIVE: EFF SER 37-0979  
THRU SER 37-1225  
DATE: 10-16-69  
JWH

ITEM NO	PART NO.	DESCRIPTION	VENDOR
12	AGC-2	FUSE	
11	AGC-2	FUSE	
10	HHJ-A	FUSEHOLDER	71400
9	8755-B-6-DDS	INDICATOR LIGHT	08717
8	S-1856-1	LIMIT SWITCH	
7	S-392-1	SWITCH	
6	S-1637-1	HOUSING - PLUG	
5	S-1637-2	HOUSING - CAP	
4	VAL 3-200	RES AXIAL LEAD	94310
3	S-1560-2	CIRCUIT BREAKER	
2	1552513-1	MOTOR ASSY(REAR)	
1	1452506-4	MOTOR ASSY(FRONT)	

EQUIPMENT TABLE

CES-1000 IS APPLICABLE	SUPERSEDES
VENDOR CODES PER S-1400	SUPERSEDED BY
CES-XXXX-CESNA SPEC NO	P16.5.0
8-XXX OR CMAXX-CESNA	
STD. NO.	

REVISION		DATE		APPD	
LET	DESCRIPTION				
A	REFER TO PAGE 16.4.0 FOR REV				

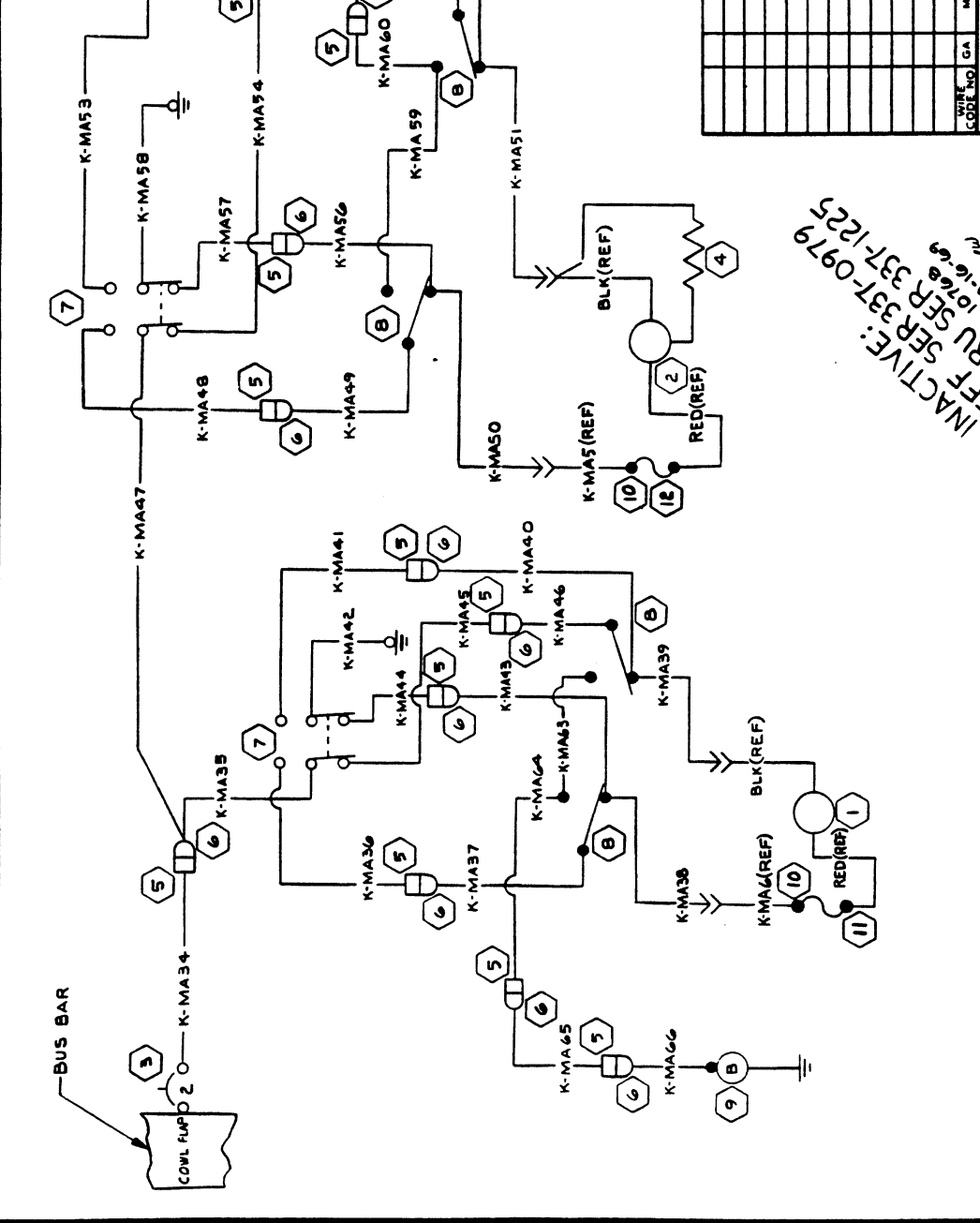

INACTIVE: SER 337-125  
 THRU SER 337-125  
 DATED 10-16-69  
 JPL  
 SER 337-125

WIRE TABLE							
WIRE CODE	NO	GA	MATERIAL	LG	TERMINALS	SERIALS	

CONTRACT NO. COMMERCIAL AIRCRAFT DIV.  
 8800 E. PAWNEE  
 WICHITA, KANSAS

DESIGN ZONKNER	DATE 5-3-69	TITLE
GROUP H. WISE	DATE 5-17-69	WIRING DIAGRAM -
DRAWN YOUNGERS	DATE 2-1-69	COWL FLAPS-FRONT&REAR
CHECK LAURIE	DATE 2-16-69	
PROJ. J. SATTLER	DATE 5-22-69	
APPD		
OTHER		

PART NO.	DESCRIPTION
	EQUIPMENT TABLE
SUPERSEDES	
SUPERSEDED BY P 16.5.1	

CES-1000 IS APPLICABLE VENDOR CODES PER S-1400 CES-XXXX-CESNA SPEC NO S-XXX OR CMXXXX-CESNA STD NO	
SIZE	CODE IDENT DWG NO
C	71379 - 1570000
SCALE: NONE	337
EDARR 01527	(SR 5441)
	PAGE: 16.4.1

INACTIVE:  
EFF SER 37-1225  
THRU 37101462

LET	REVISION	DESCRIPTION	DATE	APPD

WIRE CODE	NO	GA	MATERIAL	LG	TERMINALS	SERIALS
K-MA66	20				S-1635-1	SOLDER
K-MA65	20				S-1635-1	S-1636-1
K-MA64	20				SOLDER	S-1636-1
K-MA63	20				SOLDER	SOLDER
K-MA62	20				S-1635-1	SOLDER
K-MA61	20				S-1635-1	S-1636-1
K-MA60	20				SOLDER	S-1636-1
K-MA59	20				SOLDER	SOLDER
K-MA58	20				S-1367-1-4	S-1367-1-8
K-MA57	20				S-1636-1	S-1367-1-4
K-MA56	20				SOLDER	S-1635-1
K-MA55	20				S-1635-1	SOLDER
K-MA54	20				S-1636-1	S-1367-1-4
K-MA53	20				S-1367-1-4	S-1636-1
K-MA52	20				SOLDER	S-1635-1
K-MA51	20				S-341-2	SOLDER
K-MA50	20				S-1635-1	SOLDER
K-MA49	20				S-1367-1-4	S-1636-1
K-MA48	20				SEE RM35	S-1367-1-4
K-MA47	20				S-1635-1	SOLDER
K-MA46	20				S-1636-1	S-1367-1-4
K-MA45	20				S-1367-1-4	S-1636-1
K-MA44	20				S-1367-1-4	S-1636-1
K-MA43	20				SOLDER	S-1635-1
K-MA42	20				S-1367-1-4	S-1636-1
K-MA41	20				S-1636-1	S-1367-1-4
K-MA40	20				SOLDER	S-1635-1
K-MA39	20				SOLDER	S-341-2
K-MA38	20				SOLDER	S-341-2
K-MA37	20				S-1635-1	SOLDER
K-MA36	20				S-1367-1-4	S-1636-1
K-MA35	20				S-1635-2	S-1367-1-4
K-MA34	20				S-1367-1-4	S-1636-1
WIRE CODE	NO	GA	MATERIAL	LG	TERMINALS	SERIALS

WIRE TABLE

CONTRACT NO. **CSSNA AIRCRAFT CO.** COMMERCIAL AIRCRAFT DIV.  
 E. PAWNEE WICHITA, KANSAS

DESIGN **W-10420** DATE **10-21-69**  
 GROUP **H-1120** DATE **10-21-69**  
 DRAWN **D.G. PLAIN** DATE **10-14-69**  
 CHECK **J. HACE'S** DATE **10-21-69**

TITLE **WIRING DIAGRAM - COWL FLAPS - FRONT & REAR**

SIZE **C** CODE IDENT **71379** DWG NO **1570000**

SCALE: **NONE** PAGE: **337**

PROJ **R. L. L...** DATE **10-21-69**  
 APPD **[Signature]** DATE **10-21-69**  
 OTHER

QTY	PART NO.	DESCRIPTION	VENDOR
9	8955-B-6-D05	INDICATOR LIGHT	OB717
8	S-1850-1	LIMIT SWITCH	
7	S-392-1	SWITCH	
6	S-1637-1	HOUSING - PLUG	
5	S-1637-2	HOUSING - CAP	
4	VAL 3-200	RES AXIAL LEAD	94310
3	S-1960-2	CIRCUIT BREAKER	
2	1552513-1	MOTOR ASSY(REAR)	
1	1452306-4	MOTOR ASSY(FRONT)	

EQUIPMENT TABLE

CES-1000 IS APPLICABLE  
 VENDOR CODES PER S-1400  
 CES-XXXX-CESNA SPEC. NO.  
 S-XXX OR CXXXX-CESNA  
 STD. NO.

SUPERSEDES: **P 16.4.0**  
 SUPERSEDED BY:

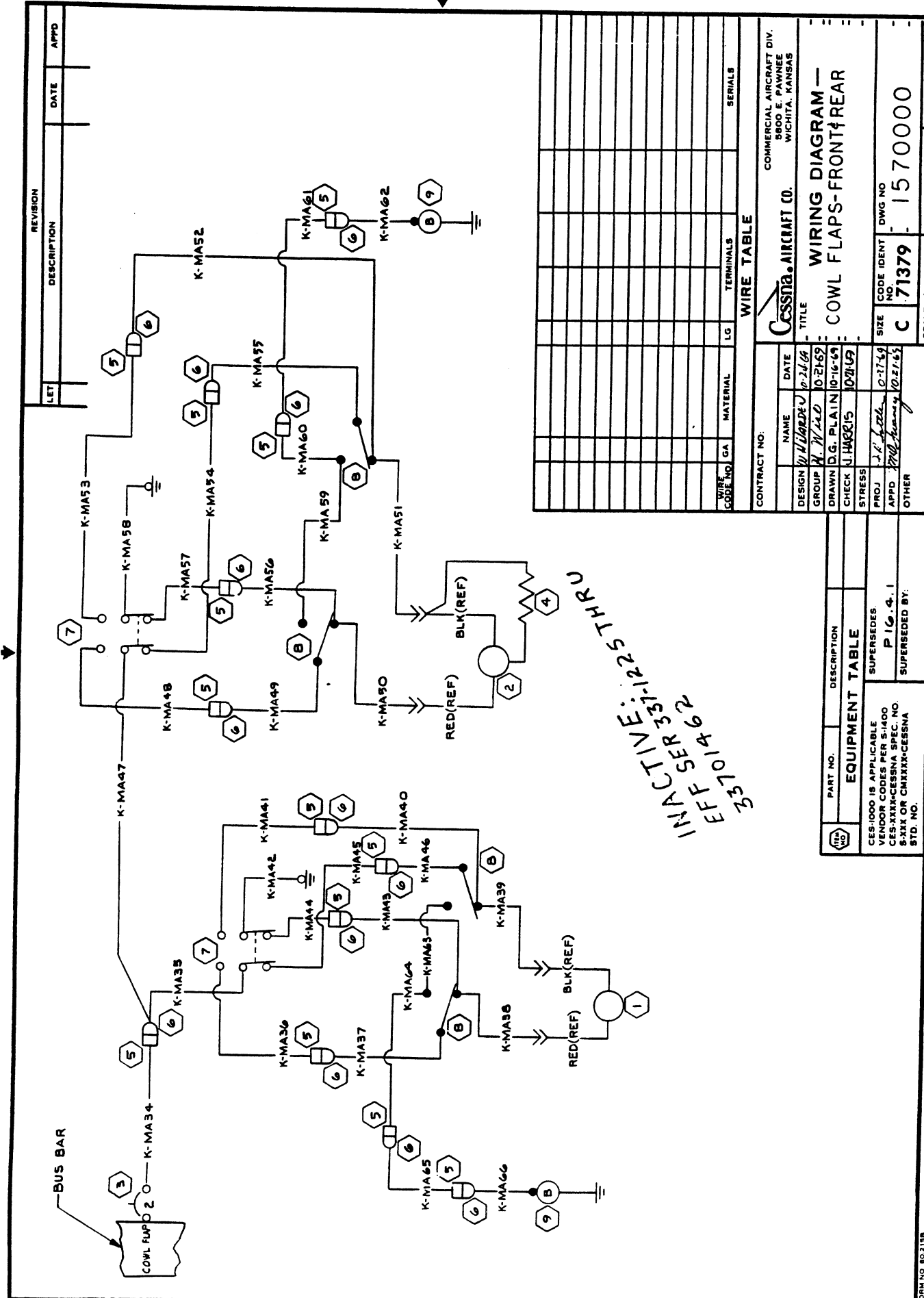

LET		REVISION	DESCRIPTION	DATE	APPD

CONTRACT NO.		COMMERCIAL AIRCRAFT DIV. CESSNA AIRCRAFT CO. 5800 E. PLAINES WICHITA, KANSAS	
DESIGN	NAME	DATE	TITLE
GROUP	A. H. L. L.	10-21-69	WIRING DIAGRAM -
DRAWN	D. S. PLAIN	10-16-69	COWL FLAPS-FRONT & REAR
CHECK	J. HARKIS	10-21-69	
STRESS			
PROJ	A. J. L. L.	10-21-69	
APPD	J. Harkis	10-21-69	
OTHER			

PART NO.		DESCRIPTION	
EQUIPMENT TABLE		CES-1000 IS APPLICABLE	SUPERSEDES:
		VENDOR CODES PER S-1400	P 16, 4, 1
		CES-XXXX-CESNA SPEC. NO.	SUPERSEDED BY:
		S-XXX OR CMXXX-CESNA	
		STD. NO.	

WIRE CODE NO	GA	MATERIAL	LG	TERMINALS	SERIALS

SIZE	CODE IDENT	DWG NO
C	71379	1570000

SCALE:	NONE	337	PAGE:	16.5.1
ED & RR	10768	SER 337-1225		FOR

FORM NO 80-118