



HN-224
DN-169
EN-60
FN-48

SERVICE BULLETIN

DATE: 15 JUNE 1990
PAGE 1 OF 3

/// MANDATORY ////////////////////////////////////// MANDATORY ////////////////////////////////////// MANDATORY ///

SUBJECT: ONE-TIME REPLACEMENT OF TAIL ROTOR BLADE PITCH ARM BOLT ATTACHING NUTS.

MODELS AFFECTED: All MD Helicopters, Inc. (MDHI) 369 Series helicopters, equipped with metal tail rotor blades.

TIME OF COMPLIANCE: The requirements of this Notice shall be accomplished within the next 300 hours of helicopter operation or at the next annual inspection, whichever occurs first.

PREFACE: MDHI installation requirements were recently revised to lower the installation torque of the tail rotor pitch link nuts. Therefore, MDHI is requiring operators to replace the subject MS17826-4 nuts. MDHI will provide operators with replacement nuts, free of charge. Contact a MDHI Approved Service Center or Distributor for replacement nuts.

<u>Nomenclature</u>	<u>PARTS LIST</u> <u>Part No.</u>	<u>Qty.</u>	<u>Source</u>
Nut	MS17826-4	A/R	MDHI

REFERENCE PUBLICATIONS:

- 369H Basic HMI (CSP-H-2) Revised 15 January 1989
- 369D/E HMI Vol. I (CSP-D-2) Revised 01 August 1989
- 369F/FF HMI Vol. I (CSP-F-2) Revised 01 June 1989
- 369DEF COM (CSP-DEF-5) Revised 29 September 1989

WEIGHT AND BALANCE: Weight and balance are not affected.

The resultant alteration to affected models as described by procedures in this Notice has been shown to comply with Federal Aviation Regulations and is FAA Approved.

/// MANDATORY ////////////////////////////////////// MANDATORY ////////////////////////////////////// MANDATORY ///

SERVICE BULLETIN

/// MANDATORY ////////////////////////////////////// MANDATORY ////////////////////////////////////// MANDATORY ///

PROCEDURE



Carefully secure the hex portion of the pitch arm bolt while removing and installing nut.

- a. Remove nuts at pitch control assembly and nuts at tail rotor blade pitch arm attachments. (Refer to Figure 1 .)
- b. Install new MS17826-4 nuts. Torque tail rotor blade nuts to **50 - 60 inch-pounds**. Torque nuts at pitch control assembly to **30 - 40 inch-pounds**.



DO NOT exceed 60 inch-pounds torque on the tail rotor blade nuts or 40 inch-pounds on the pitch control assembly nuts.

- c. Without exceeding torque limits, align cotter pin hole at the outboard and inboard ends of the pitch arm and install cotter pin.

NOTE

Apply MIL-P-8585 zinc chromate primer to cotter pin during installation.

Record compliance to this Service Information Notice in the Compliance Record section of the helicopter Log Book.

/// MANDATORY ////////////////////////////////////// MANDATORY ////////////////////////////////////// MANDATORY ///

SERVICE BULLETIN

DATE: 15 JUNE 1990
PAGE 3 OF 3

MANDATORY

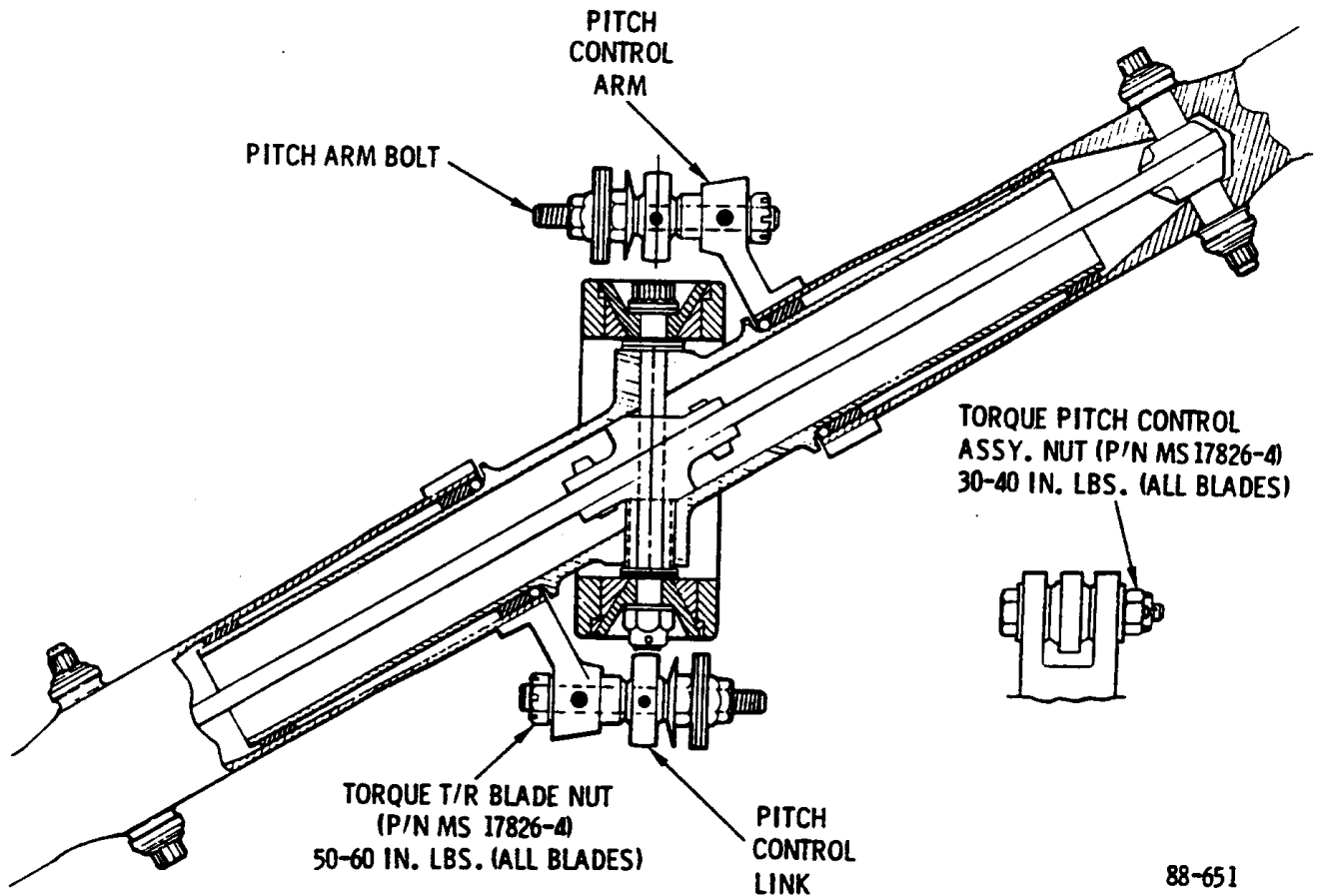

Figure 1. Replacement of Tail Rotor Pitch Link Nuts.

MANDATORY