



# SERVICE BULLETIN

DATE: 03 MARCH 1980

PAGE 1 OF 3

**/// MANDATORY ////////////////////////////////////// MANDATORY ////////////////////////////////////// MANDATORY ///**

## REMOVAL OF FILTER GASKET – ENGINE AIR INLET (PARTICLE SEPARATOR) FILTER KIT INSTALLATION, PN 369H90148 AND 369H90148–501

### 1. PLANNING INFORMATION

#### A. MODELS AFFECTED:

All 500 Model 36911 Series Helicopters equipped with subject Air Inlet (Particle Separator) Filter Kit Installations

All PN 369H190148 and 369H90148-501 Filter Kits, and PN 369H90152-3 Filter Assemblies, in Spares Inventory at date of this Notice

#### B. PREFACE:

The information given in this Service Information Notice lists a procedure for removal of the gasket material bonded to the aft side of the particle separator filter assembly in the area where the gasket does not contact the helicopter mounting structure.

#### C. TIME OF COMPLIANCE:

Shall be accomplished within next 50 hours of helicopter operation

Shall be accomplished prior to installation of Spares filter assembly or filter kit on helicopter.

#### D. FAA APPROVAL:

FAA APPROVED

#### E. WEIGHT AND BALANCE DATA:

Weight and balance not affected.

#### F. REFERENCE:

500 Series - Basic HMI, Issued 1 October 1972; Revision No. 7, 15 December 1976

500 Series - HMI Appendix A, Issued 1 October 1972; Revision No. 4, 15 December 1974

500 Series - HMI Appendix B, Issued 1 October 1972; Revision No. 6, 1 August 1976

**/// MANDATORY ////////////////////////////////////// MANDATORY ////////////////////////////////////// MANDATORY ///**



DATE: 03 MARCH 1980  
PAGE 2 OF 3

# SERVICE BULLETIN

**/// MANDATORY ////////////////////////////////////// MANDATORY ////////////////////////////////////// MANDATORY ///**

## **2. PROCEDURE – REWORK OF FILTER GASKET**

- a. Remove particle separator filter assembly. (Refer to HMI Appendix A).
- b. Trim and cut off gasket seal bonded to aft side of filter assembly at lower area of filter not in contact with mounting structure (see Figure 1).
- c. Reinstall particle separator filter assembly.
- d. Record compliance with this Notice in Compliance Record of helicopter Log Book

**/// MANDATORY ////////////////////////////////////// MANDATORY ////////////////////////////////////// MANDATORY ///**

# SERVICE BULLETIN

DATE: 03 MARCH 1980

PAGE 3 OF 3

**MANDATORY**

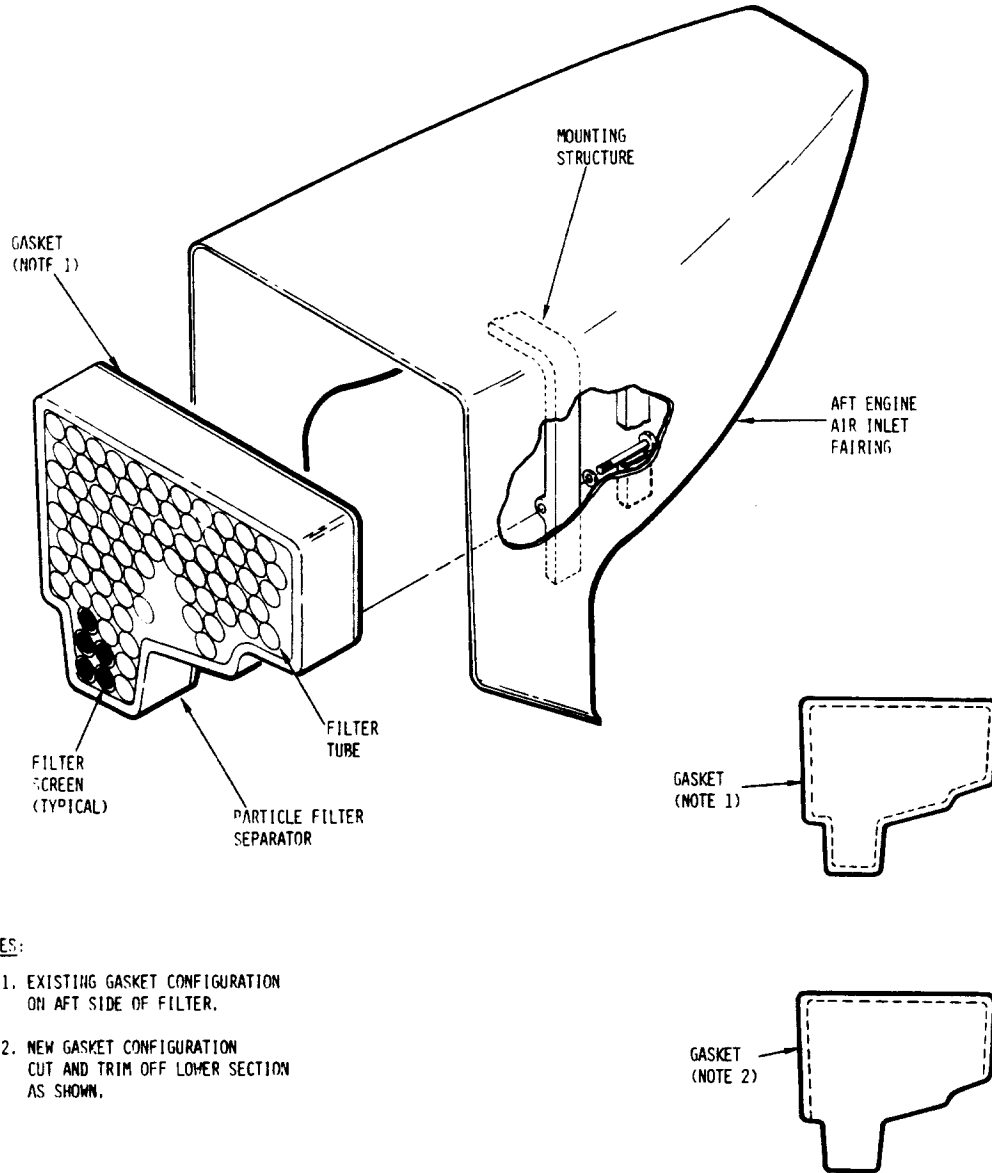

**NOTES:**

1. EXISTING GASKET CONFIGURATION ON AFT SIDE OF FILTER.
2. NEW GASKET CONFIGURATION CUT AND TRIM OFF LOWER SECTION AS SHOWN.

88-367

Figure 2. Removal of Filter Gasket - Engine Air Intake Filter Assembly

**MANDATORY**

**REFERENCE SHEET**  
**SERVICE INFORMATION NOTICES AND LETTERS**

**Action Reference:**

When performing maintenance or inspection of particle separator filter kit installation, refer to Service Information Notice No. HN-152 for removal of excess gasket material bonded to aft side of filter assembly.

**HMI Reference:**

Insert this Sheet in HMI Appendix A, Group 12, page 12--19.

This reference sheet shall be kept as a part of the manual until the data is incorporated at the next revision of HMI Appendix A. Refer to Service Information Summary, HMI Appendix A, page i.