



SERVICE BULLETIN

DATE: 1 JULY 1982

PAGE 1 OF 3

MANDATORY

REPLACEMENT OF INTERCOM (ICS) SWITCH AND JACK ASSEMBLY

1. PLANNING INFORMATION

A. Models Affected:

All 500 Model 369H Series Helicopters

B. Preface:

The information given in this Service Information Notice lists a procedure replacement of PN 369H92492 Basic or 369H92492-11 switch and jack assembly with PN 369H92492-21 switch and jack assembly. The Basic and -11 switch jack assemblies are no longer available as replacement items. Instructions are given to rework the Basic or -11 switch and jack assembly into an adapter-cable which will accommodate the new -21 switch and jack assembly.

C. Time of Compliance:

Shall be accomplished at next replacement of PN 369H92492 or 369H92492-11 switch and jack assembly.

D. Reference:

500 Model 369H Series Basic HMI, Appendix A, Publication No. CSP-H-3, Issued 1 October 1972, Revision No. 4, 15 December 1974.

E. Weight and Balance Data:

Weight and balance not affected

F. FAA Approval:

The resultant alteration to the affected Model 369H Series Helicopters, described by the replacement procedure in this Notice, has been shown to comply with Federal Aviation Regulations and is FAA Approved.

G. Parts/Supplies:

REPLACEMENT PARTS/SUPPLIES			
Nomenclature	Part No.	Qty.	Source
Switch and jack assembly (ICS)	369H92492-21	1	HHI
Jack	U-92A/U	1	Commercial

2. REPLACEMENT PROCEDURE

- (1). Disconnect headphone from switch and jack assembly.
- (2). Disconnect switch and jack assembly from bulkhead connector and remove from helicopter.

MANDATORY

DATE: 1 JULY 1982
PAGE 2 OF 3

SERVICE BULLETIN

/// MANDATORY ////////////////////////////////////// MANDATORY ////////////////////////////////////// MANDATORY ///

- (3). Rework switch and jack assembly into adapter cable as follows (see Figure 1):
 - (a). Cut cable of switch and jack assembly to desired length and discard switch.
 - (b). Remove insulation from wires in cable and solder wires to new jack. (Refer to appropriate wiring diagram in Figure 1.)
- (4). Connect adapter cable to bulkhead connector in helicopter.
- (5). Connect new switch and jack assembly to adapter cable.
- (6). Connect headphone to new switch and jack assembly.
- (7). Check intercom system (ICS) for proper operation. (Refer to 500 Series HMI, Appendix A, Group 7.)
- (8). Record compliance with this Service Information Notice in Compliance Record of helicopter Log Book.

/// MANDATORY ////////////////////////////////////// MANDATORY ////////////////////////////////////// MANDATORY ///

SERVICE BULLETIN

DATE: 1 JULY 1982
PAGE 3 OF 3

MANDATORY

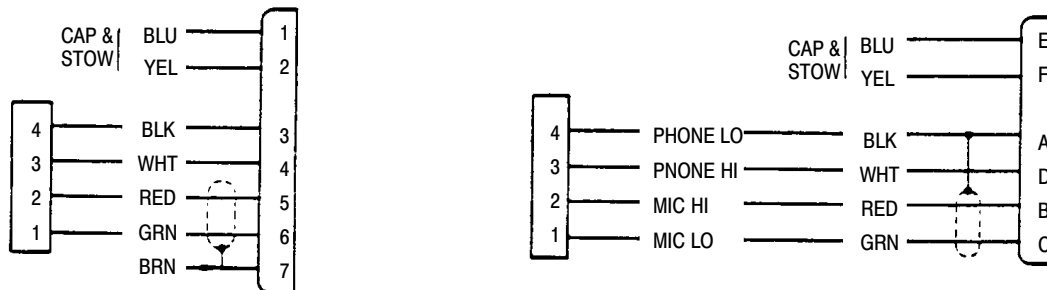
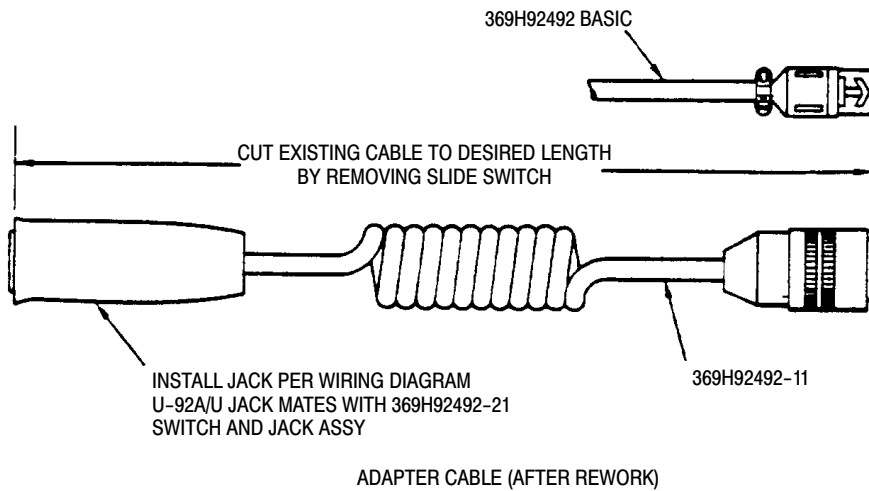
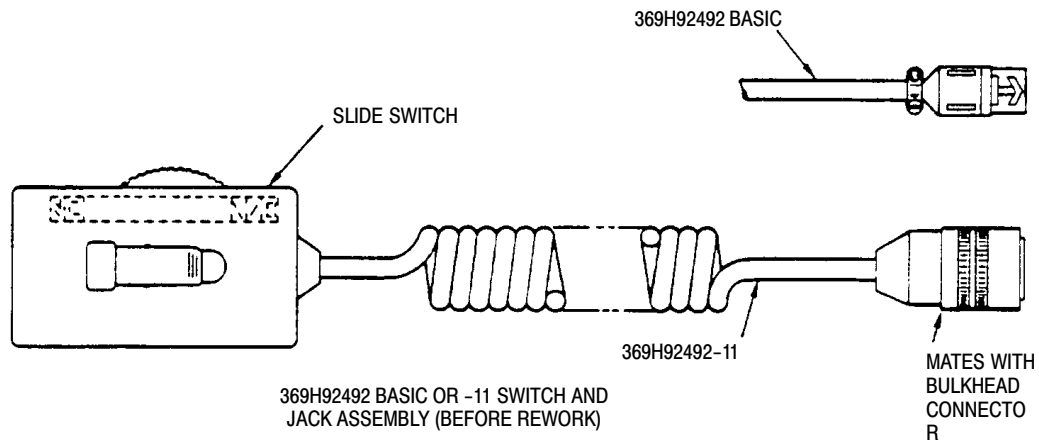

Figure 1. Rework of Intercom (ICS) Switch and Jack Assembly into an Adapter Cable.

MANDATORY