



# TECHNICAL BULLETIN

DATE: 29 JUNE 1982

PAGE 1 OF 4

## REWORK OF PN 369A9905-BASIC AND PN 369A9905-3 GROUND HANDLING WHEEL ASSEMBLIES TO ACCOMMODATE INSTALLATION OF NEW PN 369D26107 LANDING. GEAR SKID FITTINGS

### 1. PLANNING INFORMATION

#### A. Models Affected:

All 500 Model 369H Series Helicopters

All PN 369A9905-Basic (Aluminum) and PN 369A9905-3 (Steel) Ground Handling Wheel Assemblies

#### B. Preface:

Field experience has shown that the PN 369A6107 landing gear skid fitting for the ground handling wheel assemblies can be bent in service. A new PN 369D26107 attach fitting has been designed with a larger and stronger attach pin to preclude bending and breaking under load. This new improved attach fitting may be installed on all Model 369H Series helicopters as replacement, when required, for the existing sets of PN 369A6107 skid fittings.

New ground handling wheel assemblies are available to accommodate the larger attach pin on the new PN 369D26107 skid fittings. The information given in this Service Information Notice provides instructions for reworking existing ground handling wheel assemblies to the new PN 369A9905-501 (aluminum) or PN 369A9905-503 (steel) configuration, by enlarging the attach pin holes in the wheel base to accept the larger diameter pin of the new skid fittings.

It is to be noted that the new or reworked ground handling wheel assemblies (-501 and -503 configurations) are NOT to be used if early PN 369A6107 skid fittings are installed on the landing gear skids, since the smaller attach pins will bend under load in the Larger size attach pin holes.

#### C. Time of Compliance:

At owner's and operator's discretion.

#### D. Reference:

500 Series - Basic HMI, Issued 15 September 1981

#### E. Weight and Balance Data:

Weight and balance not affected

# TECHNICAL BULLETIN

DATE: 29 JUNE 1982

PAGE 2 OF 4

## F. Parts/Supplies:

REPLACEMENT PARTS/SUPPLIES			
Nomenclature	Part No.	Qty.	Source
*Bushing		2	Field Fabricate
*Required only for rework of PN 369A9905–Basic (aluminum) Ground Handling Wheel Assemblies to new PN 369A9905–501 configuration. Field fabricate per specifications, Figure 2.			

## G. Materials:

MATERIAL	
Nomenclature	Source
Primer, wet zinc chromate primer TT–P–1757	Commercial

## H. Tools and Equipment:

TOOLS AND EQUIPMENT	
Nomenclature	Source
Drill motor, portable	
Drill bit – 0.380 inch diameter (#3/8)	
Drill bit – 0.4219 inch diameter (#29/64)	
Ream bit – 0.4376/0.4405 inch diameter	

## 2. REWORK PROCEDURE

- (1). For aluminum PN 369A9905–Basic Ground Handling Wheel Assemblies only: (see Detail A, –501 configuration)
  - (a). Drill and enlarge attach pin holes in wheel base, two places, to 0.4219 inch diameter.
  - (b). Field fabricate bushings per Figure 2. Ream holes in wheel base to obtain a fit of  $-0.0024/+0.0005$  inch between hole and bushing.
  - (c). Re-identify ground handling wheel assemblies as 369A9905–501 configuration.
- (2). For steel PN 369A9905–3 ground handling wheel assemblies only: (See Detail A –503 configuration)
  - (a). Drill and enlarge existing attach pin holes in wheel base to 0.380 inch diameter; coat reworked area with wet zinc chromate primer.
  - (b). Re-identify ground handling wheel assemblies as 369A9905–503 configuration.
- (3). Check for proper installation of PN 369D21607 attach fitting pins in enlarged attach holes in reworked wheel base.

**NOTE:** DO NOT use PN 369A9905–501 or –503 ground handling wheel assemblies, if early PN 369A6107 skid attach fittings are installed on landing gear skids. (See Preface, Page 1.)

# TECHNICAL BULLETIN

DATE: 29 JUNE 1982  
PAGE 3 OF 4

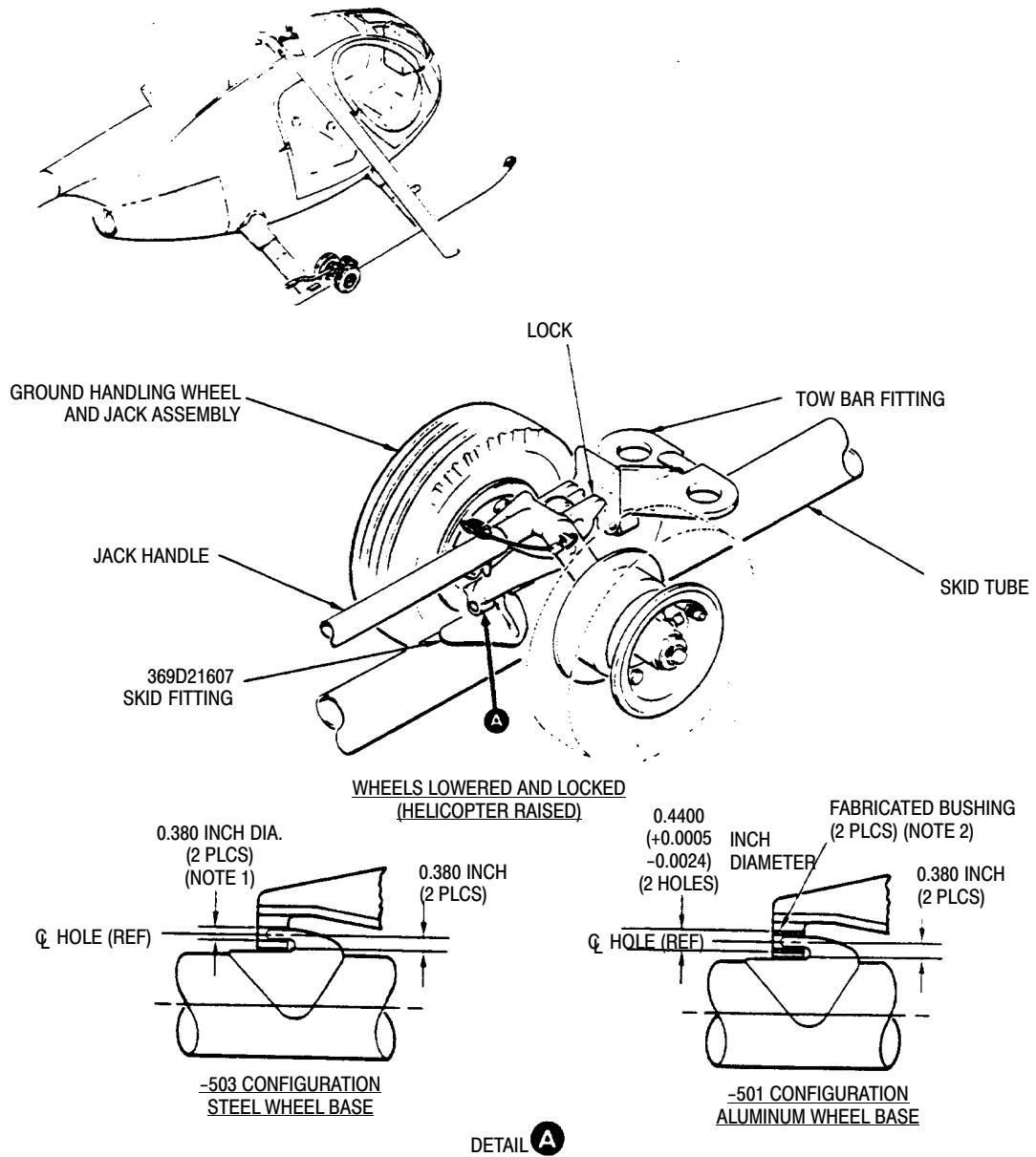

**NOTES:**

1. COAT REWORK AREA WITH WET ZINC CHROMATE PRIMER.
2. INSTALL FABRICATED BUSHING WITH WET ZINC CHROMATE PRIMER.

88-551B

**Figure 1. Rework of PN 369A9905 and 369A9905-3 Ground Handling Wheel Assemblies**

DATE: 29 JUNE 1982  
PAGE 4 OF 4

# TECHNICAL BULLETIN

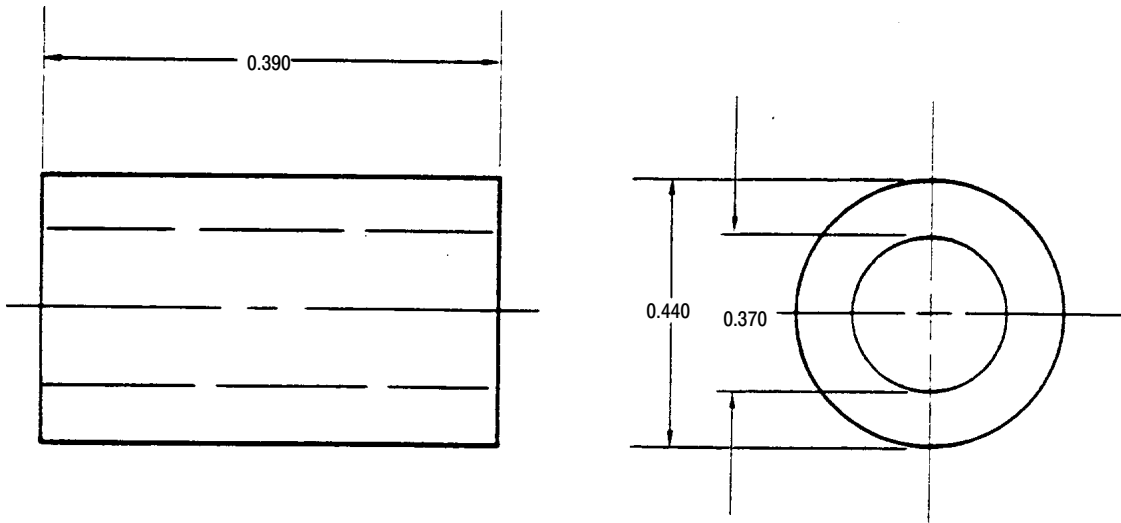

**NOTES:**

1. MATERIAL 4130 STEEL PER MIL-S-6758 OR EQUIV.
2. FINISH: CAD PLATE PER QQ-P-416 TYPE II CLASS 3  
IF CAD PLATING FACILITY IS NOT AVAILABLE,  
PAINT ALL SURFACES WITH WET ZINC CHROMATE PRIMER  
TO PREVENT CORROSION.
3. ALL DIMENSIONS IN INCHES.

88-567

**Figure 2. Field Fabrication of Bushing for Aluminum Wheel Assemblies**