

***MD HELICOPTERS INC.***

**CSP-H-4  
APPENDIX B**

**FOR**

**MDHI 369H HELICOPTERS  
REISSUED: 17 NOVEMBER 1999**

**NOTE**

This manual has been reprinted and now contains  
Revisions 1 through 5

**This Page Intentionally Left Blank**

# MDHI MODEL HELICOPTERS

## MODEL 369H

### APPENDIX B

#### AIRWORTHINESS LIMITATIONS OVERHAUL AND REPLACEMENT SCHEDULES PERIODIC INSPECTIONS WEIGHT AND BALANCE PROCEDURES

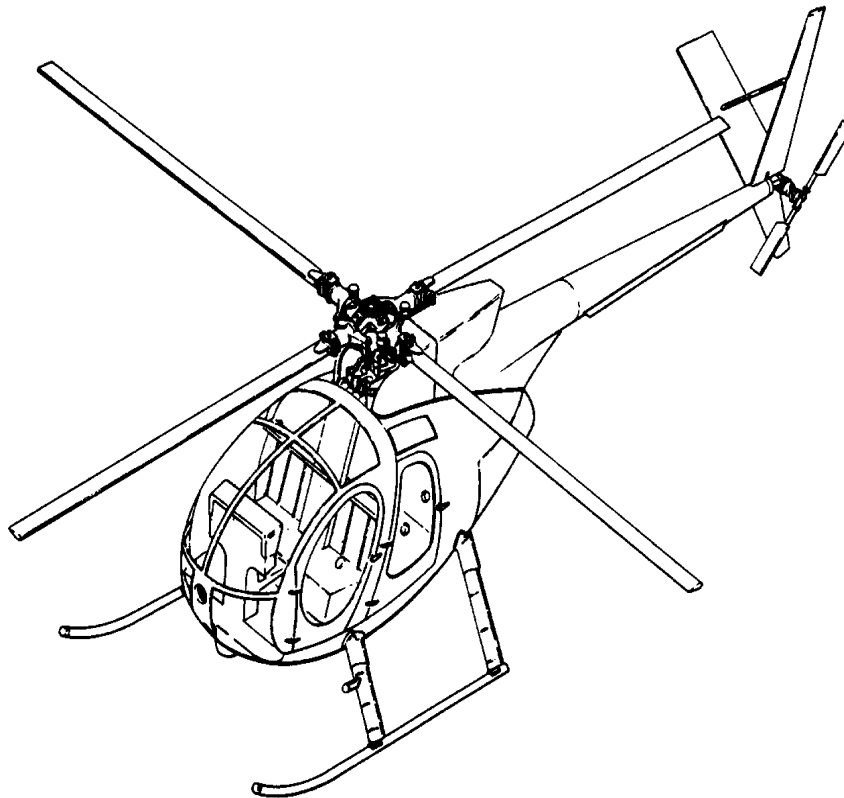

*MD Helicopter, Inc.  
4555 East McDowell Road  
Mesa, Arizona 85215-9734*

## **PROPRIETARY RIGHTS NOTICE**

**The technical data and information contained in this publication is the property of and proprietary to MD Helicopters, Inc. and is not to be disclosed or reproduced in whole or in part without the written consent of MD Helicopters, Inc.**

## **RESTRICTED USE**

**MDHI provides this manual for use by owners, operators and maintainers of MDHI products and authorized parts. Use by STC or PMA applicants or holders as documentation to support their certificates is not an authorized use of this manual and is prohibited. MDHI takes no responsibility for customer's use of parts manufactured under an STC or PMA when this manual is used as documentation with the Federal Aviation Administration to justify the STC or PMA. Use of unauthorized parts on MDHI products will void the MDHI warranty offered to the customer on components and may void the warranty on the helicopter.**

# MD HELICOPTER, INC.

## TECHNICAL MANUAL RECOMMENDED CHANGE REPORT

This manual has been prepared and distributed by the Technical Publications Department and is intended for use by personnel responsible for the maintenance of MDHI Helicopters. Periodic revision of this manual will be made to incorporate the latest information. If, in the opinion of the reader, any information has been omitted or requires clarification, please direct your comments to this office via this form (or a duplicate). An endeavor will be made to include such information in future revisions.

MD Helicopters, Inc.  
Bldg 615 M/S G048  
4555 East McDowell Road  
Mesa, AZ 85215-9734

Telephone: (800) 310-8539

Technical Publications Order Desk: (480) 346-6372; FAX: (480) 346-6821

Technical Publications Changes: (480) 346-6212; FAX: (480) 346-6809

Date: \_\_\_\_\_

Originator: \_\_\_\_\_

Address: \_\_\_\_\_

\_\_\_\_\_

\_\_\_\_\_

E-Mail: \_\_\_\_\_

Manual Title: \_\_\_\_\_ Page Number(s): \_\_\_\_\_

Chapter Title: \_\_\_\_\_ Paragraph Number(s): \_\_\_\_\_

ATA Section Number: \_\_\_\_\_ Step Number(s): \_\_\_\_\_

Issue Date: \_\_\_\_\_ Figure Number(s): \_\_\_\_\_

Revision No. and Date: \_\_\_\_\_ Table Number(s): \_\_\_\_\_

Remarks / Instructions: \_\_\_\_\_

\_\_\_\_\_

\_\_\_\_\_

\_\_\_\_\_

\_\_\_\_\_

\_\_\_\_\_

\_\_\_\_\_



# ***MD HELICOPTERS, INC.***

## **RECORD OF TEMPORARY REVISIONS**

**MANUAL TITLE: CSP-H-4 MAINTENANCE MANUAL**

REV. NO.	DATE INSERTED	BY	DATE REMOVED	BY	REV. NO.	DATE INSERTED	BY	DATE REMOVED	BY
00-001			Removed by						
00-002			Incorporating						
00-003			Revision 1						
01-001			Removed by						
01-002			Incorporating						
02-001			Revision 2						
03-001			Removed by						
			Incorporating						
			Revision 3						
06-001	06 Jul 2006	J.C.	Removed by						
07-001	<a href="#">11 Jan 2007</a>	J.C.	Incorporating Revision 5						

**This Page Intentionally Left Blank**



## LIST OF EFFECTIVE PAGES

INSERT LATEST CHANGE PAGES, DESTROY SUPERSEDED PAGES

The highest revision number indicates pages changed, added or removed by the current change.

Date of original and revised pages are:

Original (Reissue No 5) . . . . 17 November 1999	Revision 3 . . . . . 25 June 2003
Revision 1 . . . . . 14 May 2001	Revision 4 . . . . . 22 April 2004
Revision 2 . . . . . 30 January 2003	Revision 5 . . . . . 25 April 2007

Page	Revision	Page	Revision
Cover/Title	Revision 5	<b>05-00-00</b>	
<b>CR</b>		1 and 2	Revision 3
CRi/(CRii blank)	N/A	<b>05-10-00</b>	
<b>TR</b>		1 thru 4	Revision 3
1 and 2	Revision 5	<b>05-20-00</b>	
<b>LOEP</b>		1 thru 8	Revision 5
A and B	Revision 5	<b>05-20-10</b>	
<b>CONTENTS</b>		1 and 2	Original
i and ii	Revision 2	<b>05-20-15</b>	
<b>CHAPTER 01</b>		1 and 2	Revision 2
i and ii	Revision 2	<b>05-20-20</b>	
<b>01-00-00</b>		1	Revision 1
1 and 2	Original	2	Revision 2
3/(4 blank)	Revision 1	<b>05-50-00</b>	
<b>CHAPTER 04</b>		1 thru 6	Original
i	Revision 3	7 and 8	Revision 1
ii	Revision 2	<b>CHAPTER 08</b>	
<b>04-00-00</b>		i/(ii blank)	Original
1 thru 10	Revision 5	<b>08-00-00</b>	
<b>CHAPTER 05</b>		201 and 202	Original
i and ii	Revision 3	<b>08-10-00</b>	
		201 thru 211/(212 blank)	Original

**This Page Intentionally Left Blank**

## TABLE OF CONTENTS

CSP-H-4

---

[Cover / Title Page](#)

[Technical Manual Recommended Change Report](#)

[Record of Temporary Revisions](#)

[List of Effective Pages](#)

01 [Introduction](#)

04 [Airworthiness Limitations](#)

05 [Continued Airworthiness Checks / Inspections](#)

08 [Leveling / Weight and Balance](#)

**This Page Intentionally Left Blank**

# **Chapter**

# **01**

# **Introduction**



# TABLE OF CONTENTS

<b>Para/Figure/Table</b>	<b>Title</b>	<b>Page</b>
<b>01-00-00</b>	<b>Introduction</b>	<b>A</b>
	<b>Description and Operation</b>	<b>1</b>
1.	Purpose of this Appendix	1
2.	Contents of this Appendix	1
3.	ATA Numbering System and Format	1
	Figure 1. ATA Numbering System	2
4.	Page Number Blocks	2
5.	Figure and Table Numbering	2
6.	MDHI Publications Changes and Revisions	3
	A. Revision	3
	B. Reprint	3
7.	Application of Notes, Cautions and Warnings	3
8.	Service and Operations Report Form 1601	3

## TABLE OF CONTENTS (Cont.)

Para/Figure/Table	Title	Page
-------------------	-------	------

---

**This Page Intentionally Left Blank**



# **Section**

# **01–00–00**

# **Introduction**



## INTRODUCTION

### DESCRIPTION AND OPERATION

#### 1. Purpose of this Appendix

This appendix is part of the primary information file for the Model 369H Series helicopters manufactured by MD Helicopters, Inc., Mesa, Arizona. The requirements, data and instructions contained in this appendix pertain to all configurations and configuration versions of the Model 369 Series - Model 369HM (500M-Military), Model 369HS (500S-Standard) and Model 369HE (500HE-Executive).

Federal Aviation Regulations require pilots, mechanics, owners and operators to be familiar with, and to maintain records of aircraft maintenance, inspections and repairs. This includes, but is not limited to, Airworthiness Directives, Manufacturers Notices, scheduled inspections and time/cycle limited-life components.

Additional documentation is required to be available, or inside the aircraft, during operation. This documentation includes: airworthiness and registration certificates, Rotorcraft Flight Manual, weight and balance information and radio permits. It is important that all required documentation be reviewed and revised as necessary during regular inspections, maintenance and operation of the helicopter.

#### 2. Contents of this Appendix

This appendix lists the inspections required at specific operating time intervals to verify that the helicopter is airworthy. Also included are specific conditions or circumstances that might occur, overhaul and mandatory replacement schedules for limited-life parts, 100-Hour/Annual Checklist, 300-Hour Checklist, Special Inspections and Conditional Inspections which must be adhered to on helicopters operated for hire as defined under FAR Part 91. In addition, the 500 Series - Basic HMI contains weight and balance procedures for weighing and determination of correct balance for the Model 369H helicopter.

**NOTE:** Because this manual pertains to all Model 369H helicopters, it may contain inspection requirements applicable to specific equipment not installed on individual helicopters. When this situation is encountered, requirements that are not applicable should be disregarded.

- (1). The basic part number of an assembly or component may be further identified by a serial number. In most cases, the serial number consists of a two or three-digit prefix which denotes date of manufacture and a four-digit suffix which defines sequence of manufacture. For example:

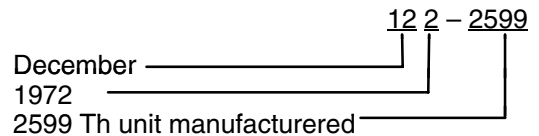

- (2). The four-digit suffix is generally used for identification purposes. Serialization of each basic part number starts with 0001 and progresses through numerical and alphanumeric combinations as follows:

0001 - 9999  
A000 - Y999  
AA00 - YY99  
AAA0 - YYY9

- (3). Where date of manufacture is not relevant, a part number may be identified by a serial number consisting only of four digits as listed above.

**NOTE:** For additional part number information, refer to the 369H Illustrated Parts Catalog (369H - IPC).

#### 3. ATA Numbering System and Format

This MDHI Maintenance Manual is prepared in general compliance with Air Transport Association Specification for Manufacturers Technical Data (ATA-100).

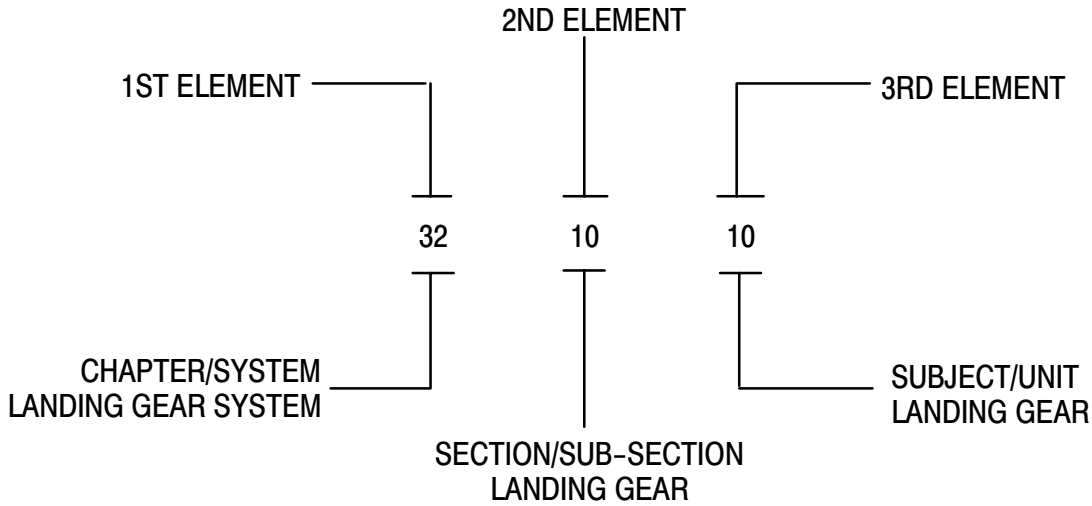

G01-0004

**Figure 1. ATA Numbering System**

**4. Page Number Blocks**

Page number blocks used for each Section in the Maintenance Manual logically arrange the material as follows:

**NOTE:**

- Maintenance Practices consists of either a brief subtopic or a combination of the following subtopics: Servicing, Removal/Installation, Adjustment/Test, Inspection/Check, Cleaning/Painting and Approved Repairs. Two methods are used for numbering maintenance practices page blocks:
- If a single subtopic or all subtopics under Maintenance Practices are brief, they are combined into one topic. All such topics are numbered within page number block 201 - 300.
- If individual subtopics become so lengthy that a combination would require numerous pages, each topic is broken out. Page number blocks accordingly are as follows:

Description and Operation .....	1
Fault Isolation .....	101
Maintenance Practices .....	201
Servicing .....	301
Removal/Installation .....	401
Adjustment/Test .....	501
Inspection/Check .....	601
Cleaning/Painting .....	701
Repairs .....	801
Initial Installation .....	901

Each page bears an effective date, either that of original issue or of the latest revision.

**5. Figure and Table Numbering**

Illustrations and tables use the same numbering as the page block in which they appear. For example, Figure 202 would be the second figure in a Maintenance Practices section. When referring to a figure or table within the same section, it is referenced as follows; (Ref. Figure 202). When referring to a figure or table within another section, it is referenced as follows; (Ref. Table 1, 91-00-00).

The uniform numbering system established by ATA-100 is used. This numbering system provides a means for dividing material into Chapter, Section, Subject and Page. The number is composed of three elements, which consist of two digits each (Ref. Figure 1). The chapter and section elements (sub-assembly 10, 20, 30, etc.) are assigned by ATA-100. Subject/Unit element numbers are assigned by MDHI.

## 6. MDHI Publications Changes and Revisions

Changes in the helicopter, equipment, maintenance practices, procedures and additional information developed by experience affect manual content. To ensure that MDHI manuals continue to reflect current changes, revised information is provided by one or more of the following communications:

### A. Revision

Alteration of portions of the manual by the replacement, addition and/or deletion of pages is accomplished by revision. The List Of Effective Pages (LOEP) that accompany each revision identifies all affected pages. Such pages should be removed from the manual and destroyed. Added or replaced pages should be inserted and checked against the LOEP.

### B. Reprint

When large numbers of changes are involved, the manual is reprinted to include all prior revisions.

## 7. Application of Notes, Cautions and Warnings

Throughout this manual, and associated manuals, Notes, Cautions and Warnings are

used to emphasize instructions or information considered to be unusual or critical.

A **NOTE** may appear in the text either before or after instructions to which it applies, depending on the relative significance of the information.

**CAUTION** and **WARNING** statements are always placed before the information or instructions to which they apply.

The conditions that warrant use of Notes, Cautions and Warnings are defined as follows:

**WARNING** Operating procedures and practices which, if not strictly observed, may result in personal injury, or loss of life.

**CAUTION** Operating procedures and practices which, if not strictly observed, may result in damage to or destruction of equipment.

**NOTE:** An operating procedure or condition that is essential to highlight.

## 8. Service and Operations Report Form 1601

MDHI Service and Operations Report Form 1601 may be used to report to MD Helicopters, Inc. in detail any service difficulties encountered with any MDHI helicopter. Use of the form is encouraged and recommended to enable MDHI to provide owners and operators improved service, support and product improvements. The form also serves as a convenient detailed record for owners and operators. Copies of the form may be procured by contacting the Product Support Dept.



# **Chapter**

# **04**

# **Airworthiness Limitations**





# TABLE OF CONTENTS

Para/Figure/Table	Title	Page
<b>04-00-00</b>	<b>Airworthiness Limitations</b> .....	<b>A</b>
1.	General .....	1
	<b>Airworthiness Limitations</b> .....	<b>3</b>
2.	Component Mandatory Replacement .....	3
3.	Component Mandatory Inspections .....	3
4.	Torque Event (TE) .....	4
5.	External Lift and Torque Event (TE) Requirements .....	4
	Table 1. Airworthiness Limitations Schedule .....	5

## TABLE OF CONTENTS (Cont.)

Para/Figure/Table	Title	Page
-------------------	-------	------

---

**This Page Intentionally Left Blank**

# **Section**

# **04-00-00**

# **Airworthiness Limitations**



## AIRWORTHINESS LIMITATIONS

Type Certificate No. H3WE

FAA Approved Airworthiness Limitations for MD Helicopters, Inc., Models 369H/HE/HS/HM.

### 1. General

The Airworthiness Limitations Section specifies maintenance required under CFR 43.16 and 91.403 of the Code of Federal Regulations unless an alternative program has been FAA approved.

REVISION:	DATE	FAA SIGNATURE AND DATE
Original Issue:	November 17, 1999	Not FAA approved
Revision 1:	May 14, 2001	<i>Michael E. O'Neil</i> 5/14/01
TR 01-001:	9 August 2001	<i>[Signature]</i> 8/9/01
Revision 2:	30 January 2003	Section 04-00-00 Not Affected This Revision TR 01-001 Previously Signed
TR 03-001:	18 June 2003	<i>[Signature]</i> 6/18/03
Revision 3:	25 June 2003	<i>[Signature]</i> 7/25/03
Revision 4:	22 April 2004	<i>Ronald Atmore</i> 4/22/04
TR 06-001:	06 July 2006	<i>[Signature]</i> 7/17/06
TR 07-001:	11 January 2007	<i>John L. Reid</i> 1/11/07

**This Page Intentionally Left Blank**

## AIRWORTHINESS LIMITATIONS

### 2. Component Mandatory Replacement

The Airworthiness Limitation Replacement Schedule specifies the mandatory replacement time, structural inspection interval and related structural inspection procedures approved per the certificate basis of the Type Certificate Data Sheet No. H3WE and CAR 6 (6.250, 6.251). At the listed finite-life, components or assemblies must be removed from the helicopter and permanently retired from service. At the listed inspection interval, the components or assemblies must be inspected in accordance with the 500 Series – Basic HMI.

**NOTE:** Refer to CFR Part 43.10 for latest requirements for the removal, installation, storage and disposition of life-limited parts.

- (1). A “life-limited” part is a physical component of the helicopter to which a maximum number of allowable operating hours or cycles are assigned. Certain assemblies and components on the helicopter have a limited life established by MDHI and approved by FAA Engineering. For example, a part with an assigned limit of 1000 hours, may accumulate 1000 hours of operation in service. Upon completion of the 1000 hours of operation, useful life of the part is ended. The finite-life assigned to different parts varies according to engineering fatigue tests, part experience, etc. The parts listed in this section must be removed from the helicopter at the finite-life indicated.
- (2). All parts not having an assigned life or stated to be of unlimited life, have a life of not less than 20,000 hours.
- (3). When a life-limited part or an assembly that incorporates a life-limited part is installed on a new or used helicopter, the nomenclature, part number, serial number, component time and current helicopter hours are recorded in the Log Book and component log for the helicopter. Whether the life-limited part is new or used, the remaining number of useful life hours and previous inspection time, if applicable, for

the part is added to the existing helicopter time. The total helicopter hours obtained then denotes the subsequent time at which the part must be removed from the helicopter or inspected.

- (4). If a life-limited item is part of an assembly, the assembly must be removed from the helicopter when the time expires. The assembly may be overhauled and restored to maximum number of hours of useful life by installing new life-limited parts plus all other parts specified in the overhaul instructions (Refer to Component Overhaul Manual).
- (5). If interchanged between different model helicopters (for instance, Model 369D to 369H), any component having a limited-life or overhaul schedule must be restricted to the lowest service life or TBO schedule indicated for the helicopter models and serial numbers affected.
- (6). An “N/A” entered in a column in Table 1 means that the component is not certified in that particular configuration helicopter.
- (7). Refer to the appropriate Allison Operation and Maintenance Manual for engine component replacement requirements.

### 3. Component Mandatory Inspections

Some components with mandatory inspection intervals require inspections to be completed in accordance with procedures detailed in other sections of this maintenance manual. The appropriate inspection procedures are referenced in the **Notes** flagged to each component to be inspected. All maintenance manual procedures which are referenced in the FAA Approved Airworthiness Limitations Component Mandatory Replacement Schedule are FAA approved procedures which cannot be changed without FAA review and approval of the proposed changes.

**4. Torque Event (TE)**

A Torque Event (TE) is defined as:

The transition to a hover from forward flight.

Any external lift operation.

**NOTE:** An external lift can either be on the cargo hook, external hoist or in external baskets.

For external lift operators, an external load is recorded as two (2) TE's (pick-up and drop-off).

Hover taxi with no external load will typically result in no TEs.

**5. External Lift and Torque Event (TE) Requirements**

The 369H/HS/HE/HM Model helicopters are multi-use helicopters. If the helicopter is used primarily for external lifts or training flights (high TE flights), there may be a reduction in inspection intervals of some components.

**CAUTION** For safe operation of the helicopter, TE's must be recorded in the Rotorcraft Log Book. Each external lift will be recorded as two (2) TE's.

- (1). Determine the number of TE's and external lifts the helicopter accumulates per hour of flight time.
- (2). Record all TE's in Rotorcraft Log Book and continue to record all TE's.
- (3). Perform required TE inspections.



**Table 1. Airworthiness Limitations Schedule**

Component (1)	Part No. (2) (3)	Models 369H/HM/HS (S/N 0001 To 0100)	Model 369HM/HS/HE (S/N 0101 & up) with 250-C18 engine, unless otherwise noted	Model 369H/HM/HS/HE (S/N 0101 & up) with 250-C20 engine, unless otherwise noted	Mandatory Inspection Hours
<b>Main Rotor System</b>					
Blade, main rotor	369A1100-501	1655 (7)	1570 (7)	1570 (7)	25 (14)(18)
		2440 (8)	2440 (8)	2440 (8)	25 (14)(18)
	369A1100-503	2440 (8)	2440 (8)	2440 (8)	25 (14)(18)
	369A1100-505	2440 (8)	2440 (8)	2440 (8)	25 (14)(18)
	369A1100-507	1750 (19)	1750 (19)	1750 (19)	25 (20)
	369A1100-507	2440	2440	2440	100 (18)
	369D21123-501 (22)	2440	2440	2440	100 (18)
	369D21123-503 (22)	2440	2440	2440	100 (18)
369A1100-511	3500	3500	3500	100 (18)	
Main rotor folding pin	369A1004	5760	5760	5760	
Hub sub-assy, main rotor	369A1201 (9)	8900	8900	8900	
	369A1201-615	8900	8900	8900	
	369A1201-619 (11)	8900	8900	8900	
Pitch housing, main rotor	369A1300	6200	6200	6200	
	369D21300	6200	6200	6200	
Retention straps, main rotor	369A1210	2774	2774	2774	300 (4)
Vertical hinge pin, main rotor	369A1220	5490	4220	4220	
	369D21220	5490	4220	4220	
Lead lag links, main rotor	369A1234	2860	2650	2650	25 (21)
	369H1203-BSC	6396	6396	6396	25 (21)
	369H1203-21	6396	6396	6396	25 (21)
	369H1203-31	6396	6396	6396	25 (14)
	369H1203-51	10600	10600	10600	
	369H1203-61	10600	10600	10600	
Drive shaft, main rotor	369A5500	6500	3960	3960	
	369A5520	1900	1740	1300	
Mast assy, main rotor	369A2014 (9)	5710	5710	5710	
	369A2014-501	5710	5710	5710	
	369A2014-601	5710	5710	5710	
	369A2014-603	5710	5710	5710	
	369D22014	10,450	10,450	10,450	

**Table 1. Airworthiness Limitations Schedule (Cont.)**

Component (1)	Part No. (2) (3)	Models 369H/HM/HS (S/N 0001 To 0100)	Model 369HM/HS/HE (S/N 0101 & up) with 250-C18 engine, unless otherwise noted	Model 369H/HM/HS/HE (S/N 0101 & up) with 250-C20 engine, unless otherwise noted	Mandatory Inspection Hours
<b>Drive Shafts, Couplings and Clutches</b>					
Engine drive shaft (Bendix only)	369A5510	3700	3700	3700	
Sprag assy, overrunning clutch	369A5364	(6)	(6)	(6)	300 (13)
	369D25351	(6)	(6)	(6)	300 (13)
Drive shaft, tail rotor	369A5518	8730	8730	8730	
Coupling, tail rotor drive shaft, (Bendix only) (15)	369A5501 (5)	7080	7080	7080	
	369H92564 (5)	N/A	7080	7080	
<b>Anti-Torque System</b>					
Gearshaft assy, tail rotor input (10)	369A5425	1800	1800	1800	
	369A5425-3	1800	1800	1800	
	369A5425-5	Unlimited	Unlimited	Unlimited	
Gearset, tail rotor Input (10)	369A5406	1800	1800	1800	
	Output (10)	369A5406	2940	2940	
Blade assy, tail rotor (fiberglass)	369A1607	2861	2861	N/A	100 (16)
	369A1710	2861	2861	N/A	100 (16)
	(aluminum)	369A1613 (17)	5600	5600	
	(aluminum)	369D21643-501 (23)	400	400	
	(aluminum)	369D21643-503 (23)	5600	5600	
	(aluminum)	369D21643-505 (23)	5600	5600	
	(aluminum)	369D21643-507 (23)	5600	5600	
Retention strap assy, tail rotor	369A1706 (12)	5100	5100	5100	
<b>Tailboom</b>					
Bolts, tailboom attach  For model 369HS and 369HE  For model 369HM  For all models with 369A1620 (aluminum blade) tail rotor installed	MS21250-05014 (alt. NAS625-14)	2600	2500	N/A	
		2600	2400	N/A	
		2400	2400	2400	

**Table 1. Airworthiness Limitations Schedule (Cont.)**

Component (1)	Part No. (2) (3)	Models 369H/HM/HS (S/N 0001 To 0100)	Model 369HM/HS/HE (S/N 0101 & up) with 250-C18 engine, unless otherwise noted	Model 369H/HM/HS/HE (S/N 0101 & up) with 250-C20 engine, unless otherwise noted	Mandatory Inspection Hours
Tailboom  369HS and 369HE  369HM  For model 369HS and 369HE with 369A1620 (aluminum blade) tail rotor installed  For model 369HM with 369A1620 (aluminum blade) tail rotor installed	369A3500-503	2674	2450	N/A	
		2674	2177	N/A	
		2030	2030	2030	
		1880	1880	1880	
	369A3500-505	Same as 369A3500-503			
Upper vertical stabilizer  For model 369HM, 369HS, and 369HE  For model 369HS and 369HE with 369A1620 (aluminum blade) tail rotor installed  For model 369HM with 369A1620 (aluminum blade) tail rotor installed	369A3625	3840	3840	N/A	
		3840	3840	3840	
		3280	3280	3280	
Horizontal stabilizer  For model 369HM, 369HS and 369HE  For model 369HS and 369HE with 369A1620 (aluminum blade) tail rotor installed  For model 369HM with 369A1620 (aluminum blade) tail rotor installed	369A3600	3150	3050	N/A	
		3450	3450	3450	
		3050	3050	3050	
<b>Floats</b>					
Emergency float kit squib cartridge	12552-1 (Holex, Inc.)	5 years	5 years	5 years	
	281993 (Walter Kidde)	5 years	5 years	5 years	
	12754-1 (Holex, Inc.)	5 years	5 years	5 years	
	5003527 (Tavco)	5 years	5 years	5 years	

**NOTES:**

- (1) Life-limited components interchanged between models or configurations must be restricted to the lowest service life indicated for the models or configurations affected. Life-limited components removed at retirement are to be mutilated/destroyed or conspicuously marked to prevent inadvertent return to service. Parts are applicable only on models under which a service life is listed. Life-limited components cannot be altered or permanently marked in any manner without compromising the part integrity. Part tagging or other record keeping system is required. Related component records must be updated each time component is removed from service.
- (2) Service life shown for the basic (no dash number) part numbers apply to all dash numbered versions unless otherwise indicated.
- (3) Applicable to all 369H models and configurations, except as noted.
- (4) Inspect in accordance with Main Rotor Strap Pack Lamination Inspection Procedure, at 300-hour intervals, or at 100-hour intervals if 2 laminates have failed in any one leg or tongue area of any strap assembly. A single cracked laminate between the shoes at the outboard end of a strap pack is cause for rejection of the hub assembly.
- (5) Used with 369H90123 Rotor Brake Kit.
- (6) With no cargo hook attached: – No retirement life assigned, refer to Section 05-10-00, Component Overhaul or Recommended Replacement Schedule.  
With cargo hook attached and no separate log: – 1800 hours  
With cargo hook attached and with separate log: – 1800 hours of external load operating time when logged separately per CFR 91.417 (Reference AD 90-19-02).
- (7) Applicable only to blade serial numbers 0001 thru 3499.
- (8) Applicable only to blade serial numbers 3500 and subsequent; and blade serial numbers A000 and subsequent.
- (9) Not used on Model 369HE.
- (10) Input and output gearshafts of 369A5406 tail rotor gearset are individually replaceable.
- (11) Used with 369H1200 main rotor hub assembly.
- (12) 3250-hours on all 369H, HE, HM and HS series helicopters which have a 369A1706 (BSC) tail rotor strap pack assembly installed in conjunction with fiberglass tail rotor blades, P/N 369A1710 (BSC), -9, -11, -13 and 369A1607 (BSC) or if strap assembly has ever been installed in conjunction with fiberglass tail rotor blades (Reference AD 89-11-05).
- (13) For helicopters equipped with a cargo hook, inspect overrunning clutch sprag assembly P/N 369A5364 or 369D25351, clutch inner race P/N 369A5353 and outer race 369A5352 every 300 hours in accordance with Overrunning Clutch Sprag Inspection (300 Hour). To establish time in service, either clutch total time with hook attached or a separate and permanent log of external load operating time per CFR 91.417, may be used (Reference AD 90-19-02).
- (14) Inspect main rotor blade root fittings and lead-lag link assemblies every 25 hours in accordance with HN-211.4 (Reference AD 95-03-13) (Ref. Sec. 7, Main Rotor Blade Upper and Lower Root Fitting Attach Lug and Lead-Lag Link Inspection (25 Hour) and Main Rotor Blade Upper and Lower Root Fitting, Attach Lug and Lead-Lag Link Inspection (100 Hour)).
- (15) Failsafe devise, P/N 369D25530 bolt and 369D25531 socket, must be used at both end of the tail rotor drive shaft in accordance with Installation of Tail Rotor Drive Shaft with Bendix Couplings Installed (Reference AD 86-20-07).
- (16) Inspect interior of blade spar for obvious corrosion penetrating the zinc primer as per HN-88 (Reference AD 75-22-04).
- (17) The 369A1613-7, -9 and -11 tail rotor blades are for military use only (OH-6A) and are not FAA certified for use on the Model 369H Series Helicopters.
- (18) Inspect upper and lower blade root fittings every 100 hours in accordance with Main Rotor Blade Upper and Lower Root Fitting, Attach Lug and Lead-Lag Link Attach Lug Inspection (100 Hour) (Ref. Sec. 7) (For main rotor blades 369A1100-501 thru -507, Reference AD 96-10-09).

- (19) The following main rotor blades have a finite life of 1,750 hours or 10,600 torque events\*, whichever occurs first;  
P/N 369A1100-507 with S/N D139 thru D203, D209 thru D223.  
\* TORQUE EVENT (TE) – A TE is recorded for every transition from forward flight to a hover (Reference Service Bulletin SB369H-243R3).
- (20) Inspect main rotor blades with 600 or more hours of operation every 25 hours of helicopter operation with a 10X magnifying glass for cracking of the lower surface of the blade emanating from the root fitting and doubler at the inboard end of the blade and to detect debonding between the blade root end fitting and doubler if missing or cracked adhesive or paint is observed. (Reference Service Bulletin SB369H-243R3) (Reference AD 98-15-26).
- (21) Inspect main rotor lead-lag links in accordance with Main Rotor Blade Upper and Lower Root Fitting, Attach Lug and Lead-Lag Link Attach Lug Inspection (25 Hour) up to a total time of 500 hours and every 15 hours thereafter and every 100 hours in accordance with Main Rotor Blade Upper and Lower Root Fitting, Attach Lug and Lead-Lag Link Attach Lug Inspection (100 Hour) until retirement of 369A1234, 369H1203-BSC and -21 Lead-Lag Link Assembly. (Reference AD 95-03-13).
- (22) The 369D21123-501, -503 main rotor blade has all the same inspections and interchangeability as the 369A1100-507 main rotor blade.
- (23) The 369D21643-501, -503, -505, -507 tail rotor blades are two-way interchangeable with the 369A1613 tail rotor blades in sets of two only.

**This Page Intentionally Left Blank**

# **Chapter**

# **05**

# **Continued Airworthiness**





# TABLE OF CONTENTS

Para/Figure/Table	Title	Page
<b>05-00-00</b>	<b>Continued Airworthiness</b>	<b>A</b>
	<b>Checks/Inspections</b>	<b>1</b>
1.	General Description of Inspections	1
A.	Airworthiness Limitations	1
B.	Continued Airworthiness	1
<b>05-10-00</b>	<b>Continued Airworthiness</b>	<b>A</b>
	<b>Component Overhaul/Recommended Replacement</b>	<b>1</b>
1.	Component Overhaul or Recommended Replacement Schedule	1
	Table 1. Component Overhaul Schedule	1
	Table 2. Component Recommended Replacement Schedule	3
<b>05-20-00</b>	<b>Continued Airworthiness</b>	<b>A</b>
	<b>100-Hour or Annual Inspection Checklist</b>	<b>1</b>
1.	100-Hour or Annual Inspection	1
	Table 1. 100-Hour or Annual Inspection	1
2.	Torque Event Attachment	7
	Table 2. Permanent Record of Torque Events	7
<b>05-20-10</b>	<b>Continued Airworthiness</b>	<b>A</b>
	<b>300-Hour Inspection Checklist</b>	<b>1</b>
1.	300-Hour Inspection	1
	Table 1. 300-Hour Inspection	1
<b>05-20-15</b>	<b>Continued Airworthiness</b>	<b>A</b>
	<b>Yearly Inspection Checklist</b>	<b>1</b>
1.	Yearly Inspection	1
	Table 1. Yearly Inspections	1
<b>05-20-20</b>	<b>Continued Airworthiness</b>	<b>A</b>
	<b>Special Inspections</b>	<b>1</b>
1.	Special Inspection Hourly and Calendar	1
	Table 1. Special Inspections Hourly	1
	Table 2. Special Inspections Calendar	2
<b>05-50-00</b>	<b>Continued Airworthiness</b>	<b>A</b>
	<b>Conditional Inspections</b>	<b>1</b>
1.	Conditional Inspections	1
	Table 1. Conditional Inspections	1

## TABLE OF CONTENTS (Cont.)

Para/Figure/Table	Title	Page
-------------------	-------	------

---

**This Page Intentionally Left Blank**

# **Section**

**05-00-00**

**Continued  
Airworthiness**



## CONTINUED AIRWORTHINESS CHECKS/INSPECTIONS

### 1. General Description of Inspections

The following Continued Airworthiness Sections specify inspections and other maintenance required under the Federal Aviation Regulations unless an alternative program has been FAA approved.

The inspection intervals designated herein are the maximum allowable and should not be exceeded. When unusual local conditions, such as environmental conditions, utilization, etc. dictate, it is the prerogative and responsibility of the operator to increase the scope and frequency of the inspections as necessary to ensure safe operation. Each item shall conform with the FAA Requirements, A.D.'s and Manufacturer Bulletins and Letters. Over flying the inspection interval, or any change desired to the requirements of this chapter, may be requested through the local aviation regulatory authority.

#### A. Airworthiness Limitations

Refer to section 04-00-00 for mandatory inspections and component mandatory retirement schedule.

#### B. Continued Airworthiness

This section contains the requirements for Component Overhaul/Recommended Replacement, 100-Hour or Annual Inspection Checklist, 300-Hour Inspection Checklist, Yearly Inspection Checklist, Special Inspections and Conditional Inspections.

- (1). **COMPONENT OVERHAUL/RECOMMENDED REPLACEMENT** (Ref. Sec. 05-10-00) is a schedule for the overhaul and recommended replacement of components and/or assemblies and scheduled maintenance checks.
- (2). **100-HOUR OR ANNUAL INSPECTION CHECKLIST** (Ref. Sec. 05-20-00) is a schedule of inspections that must be accomplished every 100 hours of helicopter operation or on a 12-month (annual) basis.  
An Annual Inspection is required on

this helicopter for continued airworthiness and may be accomplished in combination with a 100-hour inspection.

#### NOTE:

- To comply with the requirements of service bulletins which have been incorporated into the appropriate maintenance and inspection manuals, the latest 100-Hour or Annual Inspection must be used.
  - Refer to applicable Allison Engine Operation and Maintenance Manual for detailed requirements on inspection of the engine.
- (3). **300-HOUR INSPECTION CHECKLIST** (Ref. Sec. 05-20-10) is a schedule of inspections that must be accomplished every 300 hours of helicopter operation.
  - (4). **YEARLY INSPECTION CHECKLIST** (Ref. Sec. 05-20-15) is a schedule of inspections that must be accomplished on a yearly basis.
  - (5). **SPECIAL INSPECTIONS** (Ref. Sec. 05-20-20) consist of inspections that are contingent upon elapsed flight time or calendar time.
    - (a). **Special Inspections Hourly** should be referred to for additional inspection requirements that must be performed at specified periodic hourly intervals.
    - (b). **Special Inspections Calendar** should be referred to for additional inspection requirements that must be performed at specified periodic calendar intervals.
  - (6). **CONDITIONAL INSPECTIONS** (Ref. Sec. 05-50-00) includes inspection requirements for unusual or other specific conditions or circumstances that might occur.
  - (7). **WEIGHT AND BALANCE** (Ref. Sec. 08-10-00) includes data required to

perform weight and balance on the helicopter.

- (8). Federal Aviation Regulations require pilot's, mechanics, owners and operators to be familiar with, and to maintain records of aircraft maintenance, inspections and repairs. This includes, but is not limited to, Airworthiness Directives, Manufacturers Notices, Scheduled Inspections and Time/Cycle limited-life components.
- (9). Additional documentation is required to be available, or inside the aircraft, during operation. This documentation

includes: Airworthiness and Registration Certificates, Rotorcraft Flight Manual, Weight and Balance information and Radio Permits. It is important that all required documentation be reviewed and revised as necessary during regular inspections, maintenance and operation of the helicopter.

**NOTE:** Because this manual pertains to all MDHI Model 369H helicopters. It may contain inspection requirements applicable to specific equipment not installed on individual helicopters. When this situation is encountered, requirements that are not applicable should be disregarded.

# **Section**

# **05-10-00**

# **Continued Airworthiness**





## CONTINUED AIRWORTHINESS

### COMPONENT OVERHAUL/RECOMMENDED REPLACEMENT

**1. Component Overhaul or Recommended Replacement Schedule**

removed from the helicopter and scrapped at intervals specified.

Table 1 is the Recommended Overhaul Schedule. The listed components or assemblies should be removed from the helicopter and overhauled at intervals specified.

Neither the assignment of an airworthiness life to a component nor failure to assign an airworthiness life constitutes a warranty of any kind. The only warranty applicable to the helicopter and any components is that warranty included in the Purchase Agreement for the helicopter or the component.

Table 2 is the Recommended Replacement Schedule. The listed components should be

**Table 1. Component Overhaul Schedule**

Component (1)	Part Number (2)	Hours	
Main rotor transmission assembly	369A5100-709	2400	
	369A5100-707	1200	
	369A5100-707M	1200	
	369A5100-705	1200	
	369A5100-705M	1200	
	369A5100-701	1200	
	369A5100-607	1200	
	369A5100-605	1200	
	369A5100-603	1200	
	369A5100-601	1200	
Main rotor swashplate assembly	369A7609	2770	(3)(11)
Main rotor hub assembly	(5)(10) 369A1200	2650	
	369H1200	2650	
Overrunning clutch assembly	369A5350-603	1800	(4)
	369A5350-605	1800	(4)
Tail rotor transmission	369A5400-701	3000	
	369A5400-607	1800	
	369A5400-603	1800	
	369A5400-601	1800	
	369A5400	1800	
Tail rotor assembly	(6) 369A1600	2400	
	369A1620	On Cond.	
Starter/Generator	(8)(9) 369A4550	1200	
Landing gear damper	369A6300	1200	
	369H92800	1200	
	369H92801	1200	
	369H6340	On Cond.	(7)
	369H92131	On Cond.	(7)

**NOTES:**

- (1) Components interchanged between models or configurations must be restricted to the lowest service life indicated for the models or configurations affected. Components removed at retirement are to be destroyed or conspicuously marked to prevent inadvertent return to service. Parts are applicable only on models under which a service life is listed.
  - (2) Service life shown for basic part number applied to all dash-numbered versions unless otherwise indicated.
  - (3) Bearing assembly must be relubricated every 2 years or 2770 hours, whichever occurs first.
  - (4) Under some operating conditions, overrunning clutch splines and bearings may need to be regreased more often than at the 300-hour intervals.  
With no cargo hook attached, inspect and regrease bearing and splines every 300 hours (Ref. 500 Series – Basic HMI and COM, Overrunning Clutch Sprag Inspection).  
With cargo hook attached, inspect sprag assembly, inner race and outer race, regrease clutch splines and bearing every 300 hours or 300 hours of actual hook time when logged separately as per FAR 91.417 (Ref. 500 Series – Basic HMI and COM, Overrunning Clutch Sprag Inspection).
  - (5) Overhaul period for main rotor hub lead-lag dampers is the same as for main rotor hub.
  - (6) Specified overhaul intervals **DO NOT** apply to the pitch control assembly (swashplate) portion of the tail rotor configurations listed. Pitch control assemblies should be inspected as required and repaired or replaced on an individual condition basis.
  - (7) When inspected per 500 Series – Basic HMI (CSP-H-2).
  - (8) Refer to data plate to determine starter/generator manufacturer.  
Affects all dash numbered version starter/generators.
  - (9) For overhaul parts books and service bulletins, contact:  
Aircraft Parts Corp.  
160 Finn Court  
Farmingdale, N.Y. 11735  
Tele – 516-249-3053  
Datafax – 516-249-2577  
or  
Lucas Aerospace (formerly Lear Siegler Inc.)  
17600 Broadway Ave.  
Maple Heights Ohio 44137  
Tele – 216-662-1000  
Datafax – 216-663-5336
  - (10) Use only main rotor hubs rebuilt by MDHI or approved MDHI Licensees.
  - (11) The shelf life of bearings preserved with grease is limited to 4 years.
-

**Table 2. Component Recommended Replacement Schedule**

Component (1)	Part Number (2)	Hours
Lead-lag damper	369D21400-503	On Cond. (5)(7)
Tail rotor swashplate (duplex) bearings	369A7951-45	On Cond. (3)(8)
Tail rotor hub assembly	369A1725	On Cond. (4)
Bearings, oil cooler blower	369H5655-3	1200
	369H5655-5	1200
Belt, oil cooler blower	369H5648	1200
	369D25623	1200
Cyclic stick trim switch (6)	A218-100646-02	1000

**NOTES:**

- (1) Limited-life or scheduled replacement components interchanged between models or configurations must be restricted to the lowest service life indicated for the models or configurations affected. Limited-life or scheduled replacement components removed at retirement are to be destroyed or conspicuously marked to prevent inadvertent return to service. Parts are applicable only on models under which a service life is listed.
- (2) Service life shown for basic part number applied to all dash-numbered versions unless otherwise indicated.
- (3) Bearing assembly must be relubricated every 2 years or 2770 hours, whichever occurs first.
- (4) 2440-hours when interchanged from Model 369D helicopter during service life.
- (5) When inspected per 500 Series – Basic HMI (CSP-H-2).
- (6) Installed in 369D27133 grip assembly made by Guardian Electric Co., PN A218966714-00.
- (7) Inspect for deterioration every 600 hours up to a total time of 4200 hours and every 300 hours thereafter until deterioration is sufficient to retire assembly.
- (8) The shelf life of bearings preserved with grease is limited to 4 years.

**This Page Intentionally Left Blank**

# **Section**

# **05-20-00**

# **Continued Airworthiness**



## CONTINUED AIRWORTHINESS

### 100-HOUR OR ANNUAL INSPECTION CHECKLIST

#### 1. 100-Hour or Annual Inspection

This check sheet is designed to be used when performing 100-Hour or Annual inspections as defined under FAR, Part 43, Appendix D. This checklist, when completed, should be kept as a permanent part of the helicopter's records. Adherence to Maintenance Manual informa-

tion is required, and the manual should be consulted when using the checklist.

**NOTE:**

- Refer to applicable Allison engine inspection check list for required engine maintenance.
- Inspections in this table are for MDHI 369H helicopters only.

**Table 1. 100-Hour or Annual Inspection**

Registration No. _____	Serial No. _____	Helicopter Hours _____
Requirement		Initial
<b>GENERAL</b>		
Thoroughly clean helicopter and engine prior to start of inspection.		
Remove trim panels, covers and access panels as necessary.		
Ensure all placards and markings are installed.		
Ensure compliance with component mandatory retirement schedule.		
Calculate and record TE's, of all affected components, in Table 2.		
Ensure compliance with component overhaul schedule.		
Ensure compliance with all applicable airworthiness directives, service notices and special inspections.		
Review aircraft maintenance records for recorded discrepancies and correct discrepancies as applicable.		
Refer to related manufacturer's publications for detailed requirements on inspection of engine, starter/generator, battery and all installed STC equipment.		
<b>EXTERIOR</b>		
* Air intake for cleanliness and foreign matter.		
* Visible portion of engine compressor inlet for foreign object damage.		
<b>CAUTION:</b> Ensure that compressor cover is installed to prevent FOD.		
Engine air plenum chamber for:		
* Damage and cleanliness.		
* Wear and security of internal components.		
* Particle separator mounting structure for cracks or damage.		
Fuselage upper surfaces for:		
* Damage and condition.		
* Mast base drain holes clean and free of debris (blow air thru holes to ensure no clogging).		
* Engine air inlet fairing free from damage. No delamination noted. Access door operationally checked. Seals free from damage.		
* Engine compartment doors for proper operation of latches and closure, distortion, damage, cracks and security.		

**Table 1. 100-Hour or Annual Inspection**

Registration No. _____	Serial No. _____	Helicopter Hours _____
Requirement		Initial
Fuselage for:		
* Damage and condition.		
* Compartment fresh air vents in doors and front of canopy for easy of operation and security.		
* Fuel cell vent fairings free of obstructions and obvious damage.		
* Pilot's and passenger/cargo compartment doors for condition of door glass, vents and proper operation of latching and locking mechanisms.		
* Door hinges and pins for play or wear. Ensure door pin locking tab is engaged with slot in frame.		
* No evidence of oil leakage around fuselage drain holes.		
* Aft fuselage internal skin surface, located directly above engine compartment, for evidence of cracks. Observe area through tail rotor control bellcrank access door.		
Sta. 142.0 tail rotor control bellcrank support for cracking or damage, use bright light and mirror.		
* Check for no gap between tailboom and fuselage at attach points.		
* Check tailboom skin around stabilizer fittings for cracks.		
* Tailboom attachment-to-fuselage for security, evidence of corrosion or cracks, loose rivets or buckling.		
Vertical stabilizers for:		
* Damage to leading and trailing edges and damaged stressed side panels.		
* Mounting fittings for cracks and security.		
* Stabilizer attach bolts for security.		
* Tail skid for obvious damage and security.		
Horizontal stabilizer for:		
* Skin damage and loose rivets.		
* Lower surface drain holes for clogging.		
* Gaps between upper and lower doublers and stabilizer skin.		
Stabilizer strut for:		
* Skin damage and loose rivets.		
* Mounting fittings for cracks and security.		
<b>LANDING GEAR</b>		
Landing gear for:		
* Skid tubes and fairings for wear and damage in excess of permissible limits.		
* Upper fairing fillets for freedom of movement and general condition.		
* Strut attachment points for security and pivot (swivel) bearings for excessive play.		
* Landing gear dampers for correct extension, security of attachment and for signs of fluid leakage. Pivot bearings for excessive play.		
* Remove landing gear fairing fillets and visually inspect landing gear strut assemblies for cracks and damage.		
* Remove plug button from underside of fairing assembly. Using a bright light and 10X magnifying glass, inspect rivet hole in underside of strut for cracks. If crack is found, strut must be scrapped.		



**Table 1. 100-Hour or Annual Inspection**

Registration No. _____	Serial No. _____	Helicopter Hours _____
Requirement		Initial
<b>CABIN</b>		
Compartment heat and anti-icing valve controls for:		
* Easy and correct operation and rigging.		
* Heating system heat diffusers for security.		
* Seat belts for condition and security.		
* Inertia reels for condition and proper extension/retraction.		
Pilot/copilot controls for:		
* Wear, looseness and general condition.		
* Quick-release pins for condition.		
* Cyclic, collective and anti-torque controls for free movement.		
* Cyclic trim actuators for security.		
* Collective torque tube support bracket and bungee support bracket for evidence of cracks, gouges or other visible damage in attach lug areas; gaps between bracket and cradle cap of collective torque tube (use bright light and mirror).		
* N <sub>1</sub> power controls for obvious damage.		
* Check for minimum cyclic friction adjustment (resistance to turning spring with fingers).		
* Flight control system one-way lock (Uniloc) for oil leakage, condition and security. Fluid reservoir 1/2 – 3/4 full; replenish if low.		
<b>NOTE:</b> With main rotor blades stationary, some friction drag is felt in the cyclic. The collective also has some drag, plus resistance of the collective bungee spring. Heavy drag is an indication of droop stop deformation caused by droop stop pounding.		
Engine N <sub>1</sub> and N <sub>2</sub> power controls for:		
* Free movement, full travel, security, obvious damage and proper rigging.		
* Pilot's and copilot's throttle rigging checks at <b>FULL, GROUND IDLE</b> and <b>CUTOFF</b> positions.		
<b>MAIN ROTOR</b>		
Main rotor mixer control push-pull rods, links, scissors and bellcranks for excessive bearing play, bent rods or links, worn bushings and cracked bellcranks or brackets; all rodends centered.		
Main rotor pitch control link assemblies, upper and lower rod end bearing for evidence of axial play and for any extrusion, displacement or damage to the bearing teflon liner. Check that all rodends are centered and security of lockwire.		
Swashplate for evidence of galling or corrosion of spherical bearing, and seals for deterioration and evidence of grease leakage. Upper and lower dust boots free from damage and security. Swashplate interrupters and magnetic pick-up secure.		
Main rotor hub retention strap assemblies for breaks or cracks in strap pack laminations. Check visible portions of both lead and lag legs of pack in each pitch housing.		
Outboard ends of main rotor hub retention strap assemblies for gaps between pack laminates.		
* Main rotor hub feathering bearings for excessive wear (Ref. Main Rotor Hub Inspection).		
* Main rotor droop stop ring for corrosion, dents and scratches.		
* Main rotor droop stop striker plate rollers for play and excessive wear.		
Main rotor blade damper assemblies for obvious damage, security and excessive play in blade and pitch housing bearings.		

**Table 1. 100-Hour or Annual Inspection**

Registration No. _____	Serial No. _____	Helicopter Hours _____
Requirement		Initial
Elastomeric dampers for bonding of elastomeric material and corrosion.		
Friction dampers for oil leakage and correct low friction stage torque.		
Using bright light and 5X magnifying glass, inspect all main rotor hub assembly lead-lag links for corrosion, discoloration, pitting, intergranular cracks or stress corrosion cracks. Any discoloration or pitting is evidence of more than superficial corrosion, and the main rotor hub must be removed for replacement of lead-lag links.		
Main rotor hub bearings for roughness by rotating main rotor assembly several times by hand and listening for unusual noise.		
<b>NOTE:</b> Do not confuse with normal no-load transmission and overrunning clutch noise.		
Main rotor blade and damper attach pins tight and levers properly locked.		
Entire trailing edge and tabs for nicks, scratches and cracks generating from trailing edge (Ref. Main Rotor Blade Inspection).		
<b>WARNING: Using a 5X to 10X magnifying glass, inspect area adjacent to root fitting attach lugs and doublers for cracks and security.</b>		
Inspect lower blade root fittings every 100 hours in accordance with Main Rotor Blade Upper and Lower Root Fitting, Attach Lug and Lead-Lag Link Attach Lug Inspection (100 Hour) (Ref. Sec. 7).		
Using a bright light and 10X magnifying glass, inspect main rotor blade abrasion strips for security of bonding on lower and upper surfaces, and by tapping at bond lines. Any blisters, bubbling or lifting of abrasion strip indicates a void.		
Tip area of main rotor blades for evidence of corrosion; pay particular attention to mating area of blade skin-to-tip weight interface; verify integrity of sealant coating.		
Drain holes in main rotor blade aft tip cap and vent holes in lower skin for clogging. Main rotor tip caps for security and evidence of corrosion.		
<b>DRIVE TRAIN</b>		
Main transmission lubrication and cooling system for:		
* Main transmission case and cooling installation for evidence of leakage and security of attachment.		
* Oil cooler blower, mount, ducting and hardware for security and damage.		
* Tach generator for security and deterioration; wiring for chafing.		
* Pressure switch for security and deterioration; wiring for chafing.		
Rotor brake for:		
* Pucks and disc for wear and general condition.		
* Hydraulic lines for security and leaks.		
* Master cylinder for leaks.		
* Air in system (spongy feel at brake actuating handle when force is applied).		
Overrunning clutch for:		
* Evidence of oil leakage.		
* Proper operation: turn rotor in forward direction by hand – engine must decouple; turn rotor in reverse direction – engine must rotate (listen for turbine noise during reverse rotation). Rotor brake disc should not drag.		

**Table 1. 100-Hour or Annual Inspection**

Registration No. _____	Serial No. _____	Helicopter Hours _____
Requirement		Initial
<p><b>NOTE:</b> Normal seal drag may be sufficient to rotate engine at low rpm.</p> <p>Engine-to-main transmission drive shaft couplings and shaft for condition and security of attachment.</p> <p><u>Bendix couplings only:</u> inspect shaft coupling diaphragms for scratches, nicks or cracks.</p>		
<p><u>Bendix couplings only:</u> Check tail rotor blade tip movement in excess of 0.75 inch (19.05 mm), without main rotor blade movement, when tail rotor blades are rocked back and forth in plane of rotation.</p>		
<p>Tail rotor drive shaft for:</p> <ul style="list-style-type: none"> <li>* Evidence of buckling, dents, bulkhead chafing and obvious damage.</li> <li>* Align aft coupling index stripe with corresponding tail rotor transmission stripe and verify that bulkhead-to-drive shaft index stripes align.</li> </ul>		
<b>ANTI-TORQUE</b>		
<p>Tail rotor transmission for:</p> <ul style="list-style-type: none"> <li>* Corrosion, excessive oil leakage, cracks and other damage.</li> <li>* Check torque of mounting bolts. Safety and re-apply torque stripe.</li> </ul>		
<p>Tail rotor and pitch control assembly for:</p> <ul style="list-style-type: none"> <li>* Binding and unusual sounds (teeter blades to check for binding).</li> <li>* Control rod, pitch control links, hub and drive fork for play or damage.</li> <li>* Boots for installation and deterioration.</li> <li>* Retaining nut and lockwasher secure (no broken tangs noted and nut has not rotated, visual inspection of torque stripe).</li> <li>* Pitch control for evidence of seal rotation or loss of grease.</li> <li>* Swashplate for security and obvious damage. Check slippage mark for alignment.</li> </ul>		
<p>Drive fork for;</p> <ul style="list-style-type: none"> <li>* Elastomeric bearing elements for bond failure.</li> <li>* Apply teetering force by hand (stop-to-stop) to rotor blades and inspect elastomers for radial-molded ridges on each bearing face. Discontinuity in molded ridges indicates bearing failure. There should be no apparent motion between the cage and fork, observed motion indicates bond failure.</li> </ul> <p><b>NOTE:</b> Light swelling, pock marks and crumbs are surface conditions and do not indicate bearing failure.</p>		
<p>If equipped with conical-type teetering bearings, torque check teeter bolt.</p> <ul style="list-style-type: none"> <li>* Conical bearings for axial or radial play (no play allowed).</li> </ul>		
<p>Tail rotor blades for:</p> <ul style="list-style-type: none"> <li>* Evidence of damage, including leading edges, trailing edges, skin.</li> <li>* Open vent and drain holes.</li> <li>* Loose or damaged tip caps.</li> <li>* Rivets securing tip cap for installation and condition.</li> <li>* Abrasion strips free of damage, no excessive erosion noted and no separation in bond around edges or at tip end of blade.</li> <li>* While holding hub stationary, check tail rotor blade pitch bearings for lead-lag play in excess of 0.250 inch (6.35 mm) at blade tip. If excess play is found, remove blades, replace pitch bearings and inspect hub-to-pitch bearing contact surface of hub (Ref. COM).</li> </ul>		

**Table 1. 100-Hour or Annual Inspection**

Registration No. _____	Serial No. _____	Helicopter Hours _____
Requirement		Initial
Perform Tail Rotor Balance.		
<b>ELECTRICAL</b>		
<b>NOTE:</b> When possible, use auxiliary power source, not battery, during <b>POWER ON</b> inspection.		
XMSN OIL TEMP, FUEL FILTER and CHIPS warning lights; electrical circuits for continuity to lamps by connecting jumper wire from each sender or chip detector terminal stud to an unpainted grounding surface; check each light for illumination.		
Push <b>PRESS TO TEST</b> switch: all caution and warning lights <b>ON</b> ; depress instrument light rheostat knob; verify <b>CAUTION</b> lights dim.		
Conduct operational check of automatic reignition system; igniter noise heard and reignition indicator light functions. Reset as required.		
<b>CAUTION:</b> Do not leave landing light <b>ON</b> for more that one minute during next check; lamp will overheat and lamp life will be shortened.		
Exterior lighting (landing, position and anti-collision lights) for proper operation; all switches <b>OFF</b> after check.		
<b>WARNING:</b> Do not leave pitot heater <b>ON</b> for more than one minute during next check; severe burns to personnel may result.		
PITOT HTR switch <b>ON</b> for a few seconds. Heated pitot tube will feel warm to the touch; turn switch to <b>OFF</b> after check.		
Clean battery and inspect for: * Connector pins for evidence of corrosion. * Leakage (if battery is leaking (wet), remove and replace battery). * Battery case for cracks in support flanges. * Dc wiring for chafing caused by wiring rubbing against battery case. * Deep cycle charge (recondition) battery every 100 hours or on conditional basis at operator's discretion.		
Functionally check and inspect all installed avionics, auxiliary or optional systems and equipment. Do not actuate hoist guillotine or emergency floats.		
<b>ENGINE COMPARTMENT</b>		
Exhaust stack(s) and exhaust supports for cracks, defects and improper attachment.		
Engine compartment plumbing and electrical relay installation on left or right side oleo (landing gear damper) support fitting for good condition and security of mounting. Diodes for broken terminals and wires. Diode bracket for security and corrosion.		

**Table 1. 100-Hour or Annual Inspection**

Registration No. _____	Serial No. _____	Helicopter Hours _____
Requirement		Initial
Entire engine for:		
* Loose bolts; loose or broken connections.		
* Accessories for security and broken or missing lockwire.		
* Fuel and oil lines for chafing and kinking.		
* Fuel drain line valve for leakage.		
* Oil cooler and cooler deflector for security and obvious damage.		
* Accessible areas for obvious damage; evidence of fuel and oil leaks.		
* Engine mounts for cracks and play in mounting hardware at engine and airframe (retorque any loose mounting bolts).		
* Fuel control and compressor exterior for condition and security.		
* RPM governor lever control rod (replace if aluminum).		
Clean and lubricate drive splines of starter-generator drive shaft, and female splines in engine accessory gear case on dry spline installations.		
Anti-ice air tubes and compressor scroll for cracks or breaks at the anti-ice air valve and bleed port. If cracks exist, check engine for possible vibration causes.		
<b>AFTER INSPECTION</b>		
Touch-up all damaged paint and exterior markings, as necessary.		
Ensure all fluid levels are correct; service as required.		
Perform operational check of particle separator filter.		
Install or close all stressed panels, covers and trim panels removed or opened for inspection. Check closure, fit and security. All loose equipment for proper stowage.		
<b>CAUTION:</b> Helicopter must not be flown unless controls access panel and fuel cell access panels in cargo compartment are securely installed. These are stressed panels.		
<b>POST INSPECTION RUN UP</b>		
See applicable Pilot's Flight Manual for cockpit check and engine starting procedures. For troubleshooting procedures, refer to applicable section of this manual.		
<b>100-HOUR OR ANNUAL INSPECTION CERTIFICATION</b>		
It is certified that this helicopter has been thoroughly inspected as required by FAR, found to be airworthy, and appropriate entries made in the helicopter log book. It is further certified that the helicopter conforms to FAA specifications, that all FAA Airworthiness Directives and Manufacturer's Service Notices and Maintenance Manual data have been complied with, and the helicopter records are in proper order		

Signature \_\_\_\_\_

Rating Type or Certificate No. \_\_\_\_\_

Date \_\_\_\_\_

**2. Torque Event Attachment**

permanent record.

Table 2 is to be used for calculating and recording the Torque Events (TE) of components that are affected by Torque Events (TE).

Refer to Section 04-00-00 for components requiring calculation of TE's and information pertaining to calculation of TE's.

This record of TE's should be kept as a

Component must be scrapped when it reaches maximum TE's (Ref. Sec. 04-00-00).

**Table 2. Permanent Record of Torque Events**

<b>Component</b>	<b>Part No.</b>	<b>Serial No.</b>	<b>Hours</b>	<b>TE's</b>	<b>Signature</b>

# **Section**

# **05-20-10**

# **Continued Airworthiness**





## CONTINUED AIRWORTHINESS

### 300-HOUR INSPECTION CHECKLIST

#### 1. 300-Hour Inspection

This check sheet is designed to be used when performing scheduled inspections as defined under FAR Part 91. This checklist, when completed, should be kept as a permanent part of the helicopter's records. Adherence to Maintenance Manual information is required, and the manual should be consulted when using the checklist.

#### NOTE:

- Refer to applicable Allison engine inspection check list for required engine maintenance.
- Inspections in this table are for MDHI 369H helicopters only.

**Table 1. 300-Hour Inspection**

Registration No. _____	Serial No. _____	Helicopter Hours _____
Requirement		Initial
<b>EXTERIOR</b>		
Retorque tailboom attachment bolts.		
Remove engine inlet bypass door and check latches, hinges and hardware for wear and security (Ref. Sec.12, Engine Air Inlet By-Pass Door 300-Hour Inspection). Remove and replace the latch retention cotter pin (located inside the attach "U" clamp).		
Check horizontal and vertical stabilizer attach bolts for proper torque.		
Check lower surface of horizontal stabilizer for drain holes. Also check for gaps between upper and lower doublers and stabilizer skin.		
<b>LANDING GEAR</b>		
Perform Landing Gear Inspection.		
Perform Cabin Entry Step Inspection.		
<b>CABIN</b>		
Remove instrument console base covers and inspect anti-torque pedal crossover torque tube and bellcrank for cracks, damage and security.		
Push-pull rods for excessive bearing play, wear and security.		
Inspect fuel vent system rollover valve for condition and operation.		
<b>NOTE:</b> The 369H8108-505, 369H8108M, 369H8108-501M and 503M rollover valves do not require a 300-hour inspection.		
Check oil tank for security and evidence of leakage and damage.		
<b>MAIN ROTOR</b>		
Perform Swashplate Inspection.		
Perform Lead-Lag Bolt Inspection.		
Perform Main Rotor Hub Droop Angle Check.		
Perform Main Rotor Blade Inspection.		
Inspect main rotor mast, mast base and mast base support structure for evidence of cracks. Check with bright light and 5X magnifying glass. Visually check mast support bolts for security and condition.		
Inspect hoisting eye-bolts for cracks or corrosion.		
Perform Main Rotor Drive Shaft Inspection.		

**Table 1. 300-Hour Inspection (Cont.)**

Registration No. _____	Serial No. _____	Helicopter Hours _____
Requirement		Initial
<b>DRIVE TRAIN</b>		
Remove, inspect and clean main transmission chip detectors.		
Without cargo hook: * Perform overrunning clutch Ball Bearing Inspection and Grease Repack.		
With cargo hook: * Perform overrunning clutch Ball Bearing Inspection and Grease Repack. * Clean and visually inspect clutch externally-splined shaft and mating engine power takeoff internal splines for wear. * Inspect overrunning clutch sprag.		
Remove tail rotor drive shaft and check boom fairing and tail boom for buckles, dents, bulkhead chafing and obvious damage.		
Remove tailboom control rod and inspect for wear though hard anodized surface.		
Check shaft damper for proper friction drag. Inspect damper for damage and security.		
Check forward and aft coupling bolt and socket for indication of contact, Bendix couplings only.		
<b>ANTI-TORQUE</b>		
Remove, inspect and clean chip detectors.		
Check for contact between tail rotor bellcrank and tail rotor transmission housing at extreme right pedal travel.		
Tail rotor assembly: Elastomeric teeter bearings for wear; bond between concentric metal cones and elastomer rings of bearing assembly.		
Remove blade stop for thorough inspection; in particular, check for cracks or splits in stem area.		
<b>ELECTRICAL</b>		
<b>NOTE:</b> When possible, use auxiliary power source during POWER ON inspection, not battery.		
Perform Battery Temperature Sensing Switches – Testing.		
Check TOT indicating system for proper calibration.		
<b>ENGINE COMPARTMENT</b>		
Inspect starter/generator for: * Condition of brushes, electrical connections and commutator. * Screens for clogging. * Condition of O-ring on drive spline. * Damper backplate and clutch for condition.		
Perform Fuel Filter (Bypass) Caution Light Pressure Switch Test. <b>NOTE:</b> Also, perform this operational check whenever low pressure fuel pump filter element is replaced for any reason, or if contaminated.		

# **Section**

# **05-20-15**

# **Continued Airworthiness**



## CONTINUED AIRWORTHINESS YEARLY INSPECTION CHECKLIST

### 1. Yearly Inspection

This check sheet is designed to be used when performing special inspections as defined under FAR Part 91. This checklist, when completed, should be kept as a permanent part of the helicopter's records. Adherence to Maintenance Manual information is required,

and the manual should be consulted when using the checklist.

**NOTE:**

- Refer to applicable Allison engine inspection check list for required engine maintenance.
- Inspections in this table are for MDHI 369H helicopters only.

**Table 1. Yearly Inspections**

Registration No. _____	Serial No. _____	Helicopter Hours _____
Requirement		Initial
<b>1 YEAR</b>		
<b>EXTERIOR</b>		
Perform Pitot Static System Inspection.		
Check outside air temperature probe for security and obvious damage.		
Particle separator for condition and servicing.		
<b>NOTE:</b> If equipped with a Donaldson Particle Separator, ensure O-rings for rubber boot are not deteriorated.		
<b>LANDING GEAR</b>		
Perform Landing Gear Strut Inspection (Ref. Section 6).		
<b>CABIN</b>		
* First aid kit contents and security of attachment.		
* Fire extinguisher for charge pressure and security of attachment.		
* Inspect seats, interior trim, panels and covers for damage and security.		
* Inspect seat base structure for evidence of deformation.		
* Perform Tank Vent System Inspection.		
* Actuate and visually inspect fuel shutoff valve for proper operation.		
* Inspect fuel cell sending unit for electrical terminals and wiring for security and condition.		
* Inspect wiring harness between sending unit and instrument cluster.		
* Check <b>FUEL LEVEL LOW</b> caution light for proper operation.		
Inspect instrument plumbing and electrical wiring for chafing, damage and security.		
<b>NOTE:</b> In the following inspection, do not pull on torque or oil pressure lines.		
Inspect torque and oil pressure lines from the firewall forward to the instruments for seepage, chafing, cracking, damage and security.		
<b>ANTI-TORQUE</b>		
Drain tail rotor transmission. Flush with sufficient new oil to remove sludge accumulation. Refill with new oil.		
<b>ELECTRICAL</b>		
<b>NOTE:</b> When possible, use auxiliary power source, not battery, during <b>POWER ON</b> inspection.		
Check wiring from battery connector to warning lights for continuity, use an ohmmeter.		

**Table 1. Yearly Inspections**

Registration No. _____	Serial No. _____	Helicopter Hours _____
Requirement		Initial
<b>ENGINE COMPARTMENT</b>		
Inspect firewall insulator panels for security and obvious damage.		
Inspect overrunning clutch firewall seal and engine compressor firewall (plenum chamber) seal for proper sealing and good condition.		
<b>4 YEARS</b>		
<p><b>NOTE:</b> Shelf life of bearings preserved with grease is limited to 4 years. For this reason, it is of extreme importance that bearings carry the date of last lubrication or preservation and inspection. After 2 years of shelf life, it is advisable to relubricate bearings upon installation.</p>		
Clean, inspect and relubricate (repack) main rotor swashplate bearings that have been in storage.		
Clean, inspect and relubricate (repack) tail rotor swashplate (duplex) bearings that have been in storage.		

# **Section**

# **05-20-20**

# **Continued Airworthiness**





## CONTINUED AIRWORTHINESS

### SPECIAL INSPECTIONS

#### 1. Special Inspection Hourly and Calendar

This table is a schedule of time-phase inspections that are contingent upon elapsed flight time or calendar time. These inspections require a Log Book entry. Adherence to Maintenance Manual information is required, and the manual should be consulted when using this checklist.

#### NOTE:

- Refer to applicable Allison engine inspection check list for required engine maintenance.
- Inspections in this table are for MDHI 369H helicopters only.

**Table 1. Special Inspections Hourly**

What to Inspect
<b>EVERY 15 HOURS</b>
For 369A1234, 369H1203-BSC and -21 lead-lag link assemblies with at least 500 hours, perform Main Rotor Blade Upper and Lower Root Fitting Attach Lug and Lead-Lag Link Attach Lug Inspection (25 Hour) and every 100 hours in accordance with Main Rotor Blade Upper and Lower Root Fitting Attach Lug and Lead-Lag Link Attach Lug Inspection (100 Hour) until retirement of 369A1234, 369H1203-BSC and -21 Lead-Lag Link Assembly. (Reference AD 95-03-13).
<b>25 HOURS AFTER REPLACEMENT OF TAIL ROTOR DRIVE FORK HINGE BOLT</b>
Check rotational torque of bolt by applying <b>125 inch-pounds (14.12 Nm)</b> with torque wrench. If 125 inch-pounds (14.12 Nm) torque does not rotate bolt, preload is correct (Ref. COM, Tail Rotor Pitch Control Assembly).
<b>25 HOURS AFTER INSTALLATION OF OIL COOLER BLOWER</b>
With two pounds of force applied, check belt tension for 0.17 – 0.20 inch (4.318 – 5.08 mm) deflection. Check pulley. Check pulley shaft and splines for condition. Check oil cooler blower driven pulley retaining nut for minimum torque of <b>160 inch-pounds (18.08 Nm)</b> . If loss of torque is noted, remove pulley nut and inspect pulley shaft and splines for condition. Reinstall nut and torque to <b>160 – 190 inch-pounds (18.08 – 21.47 Nm) plus drag torque.</b>
<b>EVERY 25 HOURS</b>
<b>NOTE:</b> This inspection does not apply to 369A1100-507/511 main rotor blades or the 369H1203-51/61 lead-lag links. Visually inspect exposed portion of all installed main rotor blade upper and lower root fitting attach lugs, and main rotor hub lead-lag link attach lugs for broken or cracked lugs, corrosion or other damage to the lug areas (Ref. Sec. 04-00-00, Component Mandatory Replacement Schedule).
<b>EVERY 50 HOURS</b>
On models equipped with Rotorcraft Litter Kit: visually inspect litter doors for condition and security of quick-release fasteners. Rubber gasket between window glass and door for proper sealing.
<b>EVERY 100 HOURS WITH 2 FAILED LAMINATES IN MAIN ROTOR STRAP ASSEMBLY</b>
Inspect in accordance with Main Rotor Strap Pack Lamination Inspection at 50-hours intervals if 2 laminates have failed in any one leg or tongue area of any strap assembly. A single cracked laminate between the shoes at the outboard end of a strap pack is cause for rejection of the hub assembly,
<b>EVERY 300 HOURS OR ONE YEAR (Whichever occurs first)</b>
For main transmission serviced with MIL-L-23699 oil, drain main transmission oil system; Flush with sufficient new oil to remove sludge accumulation. Replace filter if paper or clean filter if metal, and refill with new oil.

**Table 1. Special Inspections Hourly (Cont.)**

What to Inspect
<b>EVERY 300 HOURS</b>
For 369D21400–503 lead–lag dampers with at least 4200 hours, inspect for deterioration until deterioration is sufficient to retire assembly.
<b>EVERY 600 HOURS OR ONE YEAR (Whichever comes first)</b>
For main transmission serviced with Mobil SHC 626 oil, drain main transmission oil system; Flush with sufficient new oil to remove sludge accumulation. Replace filter if paper or clean filter if metal, and refill with new oil.
<b>EVERY 600 HOURS</b>
Cyclic control system for excessive slack or free play. Cyclic control stick, at grip, for play in excess of 3/8 inch (9.525 mm).
For 369D21400–503 lead–lag dampers with less than 4200 hours, inspect for deterioration until deterioration is sufficient to retire assembly.
<b>EVERY 1200 HOURS</b>
Remove and test battery over temperature sensor unit for proper operation and accuracy (Ref. Operational Check – Battery Temperature Sensing Equipment).
<b>EVERY 6000 HOURS</b>
Replace the 369H6414 Edgelighted Panel (Ref. CSP-H-3).
<b>EVERY 2 YEARS OR 2770 HOURS (WHICHEVER OCCURS FIRST)</b>
Clean, inspect and relubricate (repack) main rotor washplate bearings and main rotor hub tapered bearings (Ref. COM).
Clean, inspect and relubricate (repack) tail rotor washplate bearings (Ref. COM).

**Table 2. Special Inspections Calendar**

What to Inspect
<b>(DAILY) BEFORE FINAL SHUTDOWN IN CORROSIVE ENVIRONMENT</b>
It is recommended that before shutdown from the last flight of the day, for helicopters operating in a corrosive environment, a Tri–Flow wash be performed on the main rotor hub and strap pack assembly (Ref. Main Rotor Hub Corrosion Prevention (Tri–Flow Wash Procedure)).
<b>EVERY 6 MONTHS OR 5 INFLATIONS</b>
Inflate emergency floats to 4.5 psi (31 kPa) for one hour. Check for leaks and condition. Continue inflation to 5.5 psi (38 kPa) and check that chamber pressure relief valves operate. Pressure–test float compartments.
<b>AFTER COMPRESSOR WATER WASH/RINSE WITH PARTICLE SEPARATOR INSTALLED</b>
During engine run after compressor water wash with particle separator installed, it is recommended that scavenge air switch be switched on to remove any moisture that has accumulated in the solenoid air valve.
<b>BEFORE OPERATION OF BREEZE HOIST SYSTEM</b>
Prior to daily hoisting operations: unreel and inspect entire length of hoist cable for broken strands (cluster of 7 wires), excessive broken wires, corrosion, and security of attachment to cable drums and swivel hook. Replace cable if broken strand or excessive broken wires are noted (Refer to hoist manufacturer’s handbook).

# **Section**

# **05-50-00**

# **Continued Airworthiness**



## CONTINUED AIRWORTHINESS CONDITIONAL INSPECTIONS

### 1. Conditional Inspections

This table is a schedule of inspections that are contingent upon incidents that occur, such as hard landings, overspeed, blade strike, etc. These inspections are required only when, and because the specific conditions or incidents occur, to ensure continued airworthiness of the helicopter.

**NOTE:**

- Refer to the applicable Allison Engine Operation and Maintenance Manual for detailed requirements on inspection of the engine for specific or unique conditions comparable to those listed.
- Inspections outlined in this table should be performed, at the times and for the conditions indicated, to ensure continued airworthiness of the helicopter. When

there is the possibility of extensive damage, such as a hard landing or blade strike, the inspection outline presents the probable order in which damage occurs.

**The following inspections are progressive and should be followed in sequence until no more damage is found.**

- Inspections in this table are for MDHI 369H helicopters only.

**WARNING**

- **Any component, assembly or detailed part that is removed for overhaul must be identified as to the reason for removal.**
- **Components that require replacement must be scrapped.**

**Table 1. Conditional Inspections**

Requirement
<b>AFTER HARD LANDING</b>
<p><b>WARNING:</b> Any component, assembly or detailed part that is removed for overhaul must be identified as to the reason for removal. Components that require replacement must be scrapped.</p> <p>Main rotor blades for bending, cracks or wrinkles.</p> <p>Main rotor blade droop stops for damage.</p> <p>Main rotor hub assembly and strap pack assembly for evidence of damage.</p> <p>Accessible areas of main rotor mast assembly and transmission attachment area for damage.</p> <p>Perform Landing Gear Inspection. Forward and aft rub plates for condition.</p> <p>Perform Tailboom Inspection; retorque mount bolts.</p> <p>Inspect tailboom attachment area for damage.</p> <p>Tail rotor drive shaft and damper, tail rotor transmission and tail rotor for distortion, loose mounting or attaching parts, buckling, breaks or other damage. Tail rotor drive shaft for contact with bulkheads.</p> <p>Visually inspect engine mounts, mounting pads and firewall for damage and distortion. Inspect all suspected parts by magnetic particle or dye-penetrant methods, as applicable.</p> <p>All flight and engine control system push-pull tubes, links, bellcranks and bearings for bends, cracks, security and free movement.</p> <p>Tunnel area A-frame for distortion, buckling or any other damage.</p> <p>Fuselage fittings for bends and cracks.</p> <p>Main transmission chip detectors for metal particles.</p> <p>Main transmission mounting flanges for cracks.</p> <p>Perform Main Transmission Drive Shaft Inspection.</p>

**Table 1. Conditional Inspections (Cont.)**

<b>Requirement</b>
<p>All engine accessories for cracked flanges, loose bolts and nuts, connections and general condition.</p> <p>Engine accessory drive housing for cracks.</p> <p>Engine chip detectors for metal particles.</p> <p>Engine oil tank, supports, tubing and hoses for leaks, cracks and security.</p> <p>Fuel cells, supports, tubing and hoses for leaks, cracks and security.</p> <p>Armor for security of attachment, buckling and distortion.</p> <p>Rotor brake installation for security of attachment and disc alignment.</p>
<b>AFTER MAIN ROTOR OVERSPEED</b>
<p><b>WARNING:</b> Any component, assembly or detailed part that is removed for overhaul must be identified as to the reason for removal. Components that require replacement must be scrapped.</p> <p><b>If overspeed is between 514 and 549 (250-C18 engine) or 523 and 540 (250-C20 engine) rpm:</b></p> <p>Main rotor blades for visible damage and distortion; dampers and tip caps for security; all bond lines for evidence of separation; root doublers and attachment fittings for security. Replace any blade with visible bond line separation.</p> <p>Main rotor blade dampers for security.</p> <p>Tail rotor blades and hub for visible damage, free movement and security.</p> <p>Main rotor hub and strap pack assembly for evidence of damage.</p> <p><b>If overspeed is over 549 (250-C18 engine) or 540 (250-C20 engine) rpm:</b></p> <p>Remove main rotor hub assembly for overhaul inspections (Ref. COM).</p> <p>Remove and scrap main rotor blades.</p> <p>Remove tail rotor hub assembly for overhaul inspection.</p>
<b>AFTER MAIN TRANSMISSION OVERTORQUE BEYOND TRANSIENT LIMITS</b>
<p>Main transmission for freedom of movement.</p> <p>Main transmission chip detectors for metal particles. Re-inspect after 8 hours of operation.</p>
<b>AFTER AIRSPEED 10% BEYOND <math>V_{NE}</math> LIMIT</b>
<p><b>WARNING:</b> Any component, assembly or detailed part that is removed for overhaul must be identified as to the reason for removal. Components that require replacement must be scrapped.</p> <p>Main rotor blades for visible damage and distortion; main rotor blade dampers and tip caps for security; all bond lines for evidence of separation; root doublers and attachment fittings for security. Replace any blade with visible bond line separation.</p> <p>Main rotor hub assembly and strap pack assembly for evidence of damage.</p> <p>Main rotor blade dampers for security.</p> <p>Tail rotor blades and hub for visible damage, freedom of movement and security.</p> <p>Strut and horizontal stabilizer for skin damage and loose rivets. Vertical stabilizer for damage to leading and trailing edges and damaged stressed side panels (no repair of side panels permitted).</p> <p>Mounting fittings for cracks and security.</p> <p>Retorque stabilizer attach bolts.</p> <p>Tailboom for visible deformation, loose or missing rivets, cracks and security; attaching points to fuselage for cracks and security.</p> <p>Canopy glass for security.</p>

**Table 1. Conditional Inspections (Cont.)**

<b>Requirement</b>
<p data-bbox="440 266 1279 296" style="text-align: center;"><b>AFTER MAIN ROTOR BLADE/DRIVE SYSTEM SUDDEN STOPPAGE</b></p> <p data-bbox="201 312 1479 436">Sudden stoppage of the main rotor and rotor drive system is any rapid deceleration of the main rotor drive system. This may be caused by contact of one or more of the main rotor blades with the ground, water, snow, dense vegetation or any other object of sufficient mass to cause deceleration or impact damage to the main rotor blades.</p> <p data-bbox="201 451 1382 510">A main rotor blade strike in which one or more of the main rotor blades exceed the repair limits in the maintenance manual is defined as sudden stoppage.</p> <p data-bbox="201 525 1511 583">Sudden stoppage of the main rotor may also occur simultaneously with hard landing in which the blades contact the upper fuselage structure or the tailboom.</p> <p data-bbox="201 598 1479 657">The inspection requirements, After Main Rotor Drive System Sudden Stoppage – Level 1, is to be used when sudden stoppage of the main rotor drive system has occurred.</p> <p data-bbox="201 672 932 701"><b>After Main Rotor Drive System Sudden Stoppage – Level 1</b></p> <p data-bbox="201 716 1511 871">Perform inspection of main rotor blades. Pay particular attention to the upper and lower root fittings and attach lug areas. If inspection determines that one or more blades have separation of the trailing edge bond, due to leading edge impact, the blade is bent or shows evidence of a significant impact, and the damage occurred with the engine running, perform the additional inspection in After Main Rotor Drive System Sudden Stoppage – Level 2.</p> <p data-bbox="201 886 1495 987">Perform inspection of the main rotor hub and lead-lag link attach lugs. If the lead-lag lug is broken or the pitch housing striker strip shows evidence of contact with the main rotor hub and damage occurred the the engine running, perform the additional inspection in After Main Rotor Drive System Sudden Stoppage – Level 2.</p> <p data-bbox="201 1001 841 1031">Perform Main Rotor Strap Pack Lamination Inspection.</p> <p data-bbox="201 1045 1520 1146">Perform Main Rotor Blade and Damper Attach Pin Disassembly and Special Inspection. If a pin is found cracked or bent and damage occurred the the engine running, perform the additional inspection in After Main Rotor Drive System Sudden Stoppage – Level 2.</p> <p data-bbox="201 1161 444 1190"><u>For friction dampers:</u></p> <ul data-bbox="201 1205 732 1264" style="list-style-type: none"><li>* Inspect clevis bolt holes for elongation.</li><li>* Perform zygo-magnetic particle inspection.</li></ul> <p data-bbox="201 1287 501 1316"><u>For elastomeric dampers:</u></p> <ul data-bbox="201 1331 1484 1390" style="list-style-type: none"><li>* Perform Main rotor Damper and Attachments Inspection. If damage to a damper is suspected, perform Main Rotor Damper Weight Loading and Extension Check.</li></ul> <p data-bbox="201 1404 1435 1505">Perform Main Rotor Drive Shaft Inspection. If main rotor drive shaft is rejected for broken shaft splines, straightness or sheared shaft, perform the additional inspection in After Main Rotor Drive System Sudden Stoppage – Level 2.</p> <p data-bbox="201 1520 1187 1549">Inspect overrunning clutch sprag assembly (Ref. Detailed Inspection after Cleaning).</p> <p data-bbox="201 1564 1154 1593"><b>CAUTION:</b> Kamatic couplings are a balanced unit and cannot be disassembled.</p> <p data-bbox="201 1608 1479 1667">Perform a visual inspection of all power train drive shafts and couplings for distortion, breaks, cracks, contact with bulkheads and other damage.</p> <p data-bbox="201 1682 915 1711">Perform a visual inspection of the oil cooler blower assembly.</p> <p data-bbox="201 1726 1446 1822">Check main rotor transmission for freedom of movement. Visually check main rotor transmission mounting flanges for cracks. Inspect main rotor transmission chip detectors for metal accumulation. Reinspect chip detectors after eight hours of helicopter operation.</p> <p data-bbox="201 1837 824 1866">Perform visual inspection of main rotor flight controls.</p> <p data-bbox="201 1881 808 1911">Perform visual inspection of the anti-torque system.</p>

**Table 1. Conditional Inspections (Cont.)**

<b>Requirement</b>
<p>Perform visual inspection of engine mounts for security, cracks or misalignment.</p> <p>Perform visual inspection of the engine control linkage for bends, breaks and proper alignment.</p> <p>Inspect engine per the special inspection requirements in the appropriate Allison Operation and Maintenance Manual.</p> <p><b>After Main Rotor Drive System Sudden Stoppage – Level 2</b></p> <p><b>WARNING:</b> Any component, assembly or detailed part that is removed for overhaul must be identified as being removed due to Main Rotor Sudden Stoppage – Level 2. Components that require replacement must be scrapped.</p> <p>Overhaul main rotor hub.</p> <p>Remove and scrap main rotor drive shaft.</p> <p>Overhaul main transmission assembly (Ref. COM).</p> <p>Remove and scrap engine-to-transmission drive shaft.</p> <p>Overhaul overrunning clutch assembly (Ref. COM).</p>
<b>AFTER TAIL ROTOR BLADE STRIKE</b>
<p><b>WARNING:</b> Any component, assembly or detailed part that is removed for overhaul must be identified as to the reason for removal. Components that require replacement must be scrapped.</p> <p><b>After tail rotor blade strike, inspect the following:</b></p> <p>If equipped with Bendix couplings, remove and scrap couplings.</p> <p>Tail rotor blades for dents, nicks, scratches or separation of skin.</p> <p>Tail rotor flapping hinge bolt for damage.</p> <p>Tail rotor transmission for radial play and run-out of output shaft, cracks in mounting flanges, and chip detector for metal particles. Replace or overhaul tail rotor transmission if damage is indicated.</p> <p>Perform visual torsional twist inspection of tail rotor drive shaft to check for buckling or twisting. Align aft tail rotor drive shaft coupling index stripe with corresponding tail rotor transmission stripe. Remove left side boom fairing forward access door and verify that bulkhead-to-drive shaft index stripes align. Misaligned or missing stripes require replacement of drive shaft and Kamatics couplings, and an overhaul inspection of tail rotor transmission (Ref. COM).</p> <p>Remove tail rotor drive shaft and inspect couplings for distortion and cracks; damper, damper bracket and bulkheads for damage.</p> <p><b>NOTE:</b> If damage in excess of allowable limits due to blade strike is noted in above areas, continue with following inspections:</p> <p>Tail rotor drive fork, pitch links, swashplate, hub and pitch control bearing housing for obvious damage.</p> <p>Upper fuselage and boom tail rotor control linkage. If tail rotor control rod is damaged, ensure that all rod bulkhead grommets are in place.</p> <p>Aft frame of tailboom for cracks and boom skin for loosened or popped rivets.</p> <p>Main transmission chip detectors and transmission lube pump oil filter for metal particles.</p> <p>Main rotor hub assembly and strap pack assembly for evidence of damage.</p>



**Table 1. Conditional Inspections (Cont.)**

Requirement
<b>AFTER TAILBOOM STRIKE</b>
<p><b>WARNING:</b> Any component, assembly or detailed part that is removed for overhaul must be identified as to the reason for removal. Components that require replacement must be scrapped.</p> <p><b>If one or more main rotor blades strike tailboom while blades are rotating, inspect following:</b></p> <p>Main rotor blades for breaks, cracks, wrinkles, distortion, or other damage in excess of allowable limits.</p> <p>If excessive damage requires replacement of main rotor blade(s), inspect complete main rotor and scissors assembly, including droop stop mechanism and strap packs, for evidence of damage.</p> <p>Remove and inspect tail rotor drive shaft for impact damage, buckling or twisting; couplings for cracks and distortion; damper, damper bracket and bulkheads for damage.</p> <p>If excessive damage requires replacement of tail rotor drive shaft, replace couplings and perform overhaul inspection of tail rotor transmission (Ref. COM).</p> <p><b>CAUTION:</b> Any tailboom damage is significant (Ref. SRM).</p> <p>Perform Tailboom Inspection. Dye-check or remove and scrap tailboom attach bolts.</p> <p>Structure forward of tailboom attachment for evidence of sheet metal yielding or buckling. Pay particular attention for signs of buckling at right side forward of tailboom attachment.</p> <p>Upper fuselage and boom anti-torque control linkage. If anti-torque control rod is damaged, ensure that all rod bulkhead grommets are in place.</p> <p>Strut and horizontal stabilizer for skin damage and loose rivets. Vertical stabilizer for damage to leading or trailing edges and damaged stressed side panels (no repair of side panels permitted). Mounting fittings for cracks and security. Retorque stabilizer attach bolts. Tail skid for obvious damage and security.</p> <p>Tail rotor assembly.</p> <p>Tail rotor transmission for radial play and run-out of output shaft; cracks in mounted flanges and chip detector for metal particles.</p> <p>Main rotor brake, if installed, for condition and alignment of brake disc, calipers and security of attachment.</p> <p><b>If tailboom strike occurred during POWER ON condition, also inspect the following:</b></p> <p>Remove and inspect main rotor drive shaft, main transmission drive shaft and couplings for distortion, breaks, cracks and other damage.</p> <p>Main transmission chip detectors and transmission lube system oil filter for metal particles. Re-inspect chip detectors and oil filter after 8 hours of engine operation. Visually check transmission mounting flanges for cracks.</p> <p>Engine air inlet and plenum chamber for foreign objects; motor engine and check for unusual noise.</p> <p>Engine mounts for security, cracks or distortion.</p> <p>Engine control linkage for bends, breaks and proper operation.</p> <p>Inspect tailboom attachment area for damage; retorque mount bolts.</p>
<b>AFTER CHIP DETECTOR LIGHT COMES ON</b>
<p>Remove chip detector leads in turn, to determine which chip detector caused indicator to light.</p> <p>Remove and inspect applicable chip detector for metal accumulation.</p> <p>If an engine chip detector caused indicator to light, refer to applicable Allison Engine Operation and Maintenance Manual for complete engine magnetic plug inspection requirements.</p> <p>Replace filter for main transmission lubrication system (main transmission lube pump filter) if main transmission chip detector caused indicator to light.</p>

**Table 1. Conditional Inspections (Cont.)**

<b>Requirement</b>
If chips measure no longer than 0.125 inch (3.175 mm), drain and refill main and/or tail rotor transmission with new oil. Recheck applicable chip detectors after 4 hours of flight.
<b>AFTER ENGINE CHANGE BECAUSE OF INTERNAL ENGINE FAILURE</b>
<b>NOTE:</b> Oil coolers are <b>NOT</b> cleanable and must be scrapped if an engine failure produces metal and <b>NO</b> scavenge oil filter is installed or if a scavenge oil filter is installed and indicates a by-pass has occurred. Remove, flush and reinstall oil tank; remove and reverse flush or replace engine oil cooler. Flush all lines, fittings and associated components. <b>CAUTION:</b> Failure to bleed fuel system can result in unexpected engine flameout or power loss. Bleed fuel system. Remove and install new scavenge oil filter element (if installed).
<b>AFTER ENGINE FLAMEOUT CAUSED BY FUEL EXHAUSTION</b>
Bleed fuel system to remove any entrapped air.
<b>AFTER ENGINE SHUTDOWN USING EMERGENCY FUEL SHUTOFF VALVE</b>
Bleed fuel system to remove any entrapped air.
<b>AFTER MAIN TRANSMISSION CHANGE BECAUSE OF INTERNAL TRANSMISSION FAILURE</b>
(For main transmission testing and run-in criteria, refer to HMI Appx. C)
<b>AFTER FUEL FILTER CAUTION LIGHT COMES ON</b>
Check <b>FUEL FILTER</b> caution light and circuit for discrepancies. Perform operational check of fuel pressure switch. Remove and install new engine-driven fuel pump filter. Remove and clean gas producer fuel control filter. Clean and flush all lines and fittings. Check bypass valve per applicable Allison Engine Operation and Maintenance Manual. Inspect start pump inlet screen for contamination when large amounts of foreign material are found in the engine driven fuel pump filter (or optional airframe fuel filter, if installed). Inspect fuel cell.
<b>AFTER NEW OR REPLACEMENT MAIN ROTOR HUB IS INSTALLED</b>
Check blade static droop angle.
<b>BEFORE INSTALLATION OF NEW BATTERY</b>
Perform Battery Charging – Deep Cycling Procedure. Repeat deep cycling procedure once to ensure complete stabilization of battery.
<b>AFTER MAIN TRANSMISSION DRIVE SHAFT IS REMOVED (ENGINE INSTALLED)</b>
Check overrunning clutch for correct oil level.
<b>AFTER COOLER BLOWER IS REMOVED</b>
Oil cooler blower scroll for surface damage, cracks, separation and wear. Impeller for cracks, surface damage, and separated or deformed vanes. Blower rotating components and shroud for interior damage, wear and foreign material. Check belt tension and clearance after installation.

**Table 1. Conditional Inspections (Cont.)**

<b>Requirement</b>
<b>WHEN MAIN ROTOR DRIVE SHAFT IS REMOVED</b>
All surfaces of drive shaft for nicks, scratches and evidence of deformation; all external and internal surfaces for evidence of corrosion. Check coupling spline for cracks.
<b>AFTER LIGHTNING STRIKE</b>
<b>WARNING:</b> Any component, assembly or detailed part that is removed for overhaul must be identified as to the reason for removal. Components that require replacement must be scrapped.
<b>If lightning strike is evident on helicopter exterior:</b>
Inspect the fuselage interior and exterior, landing gear, rotor systems and ground wire connection for burn marks, cracks, pitting or other signs of high temperature stress, to determine the lightning entry and exit points.
Trace the path of the lightning strike to the extent possible using a magnetometer.
Check the magnetic compass for accuracy (the degree of inaccuracy may serve as an indicator of the severity of the strike).
Inspect all wiring.
Inspect antenna(s) for burns and pitting.
Inspect all electrically operated components and lighting systems for damage.
Inspect communications and navigation equipment for damage.
If the preceding inspections reveal major damage has occurred, proceed as follows:
Bench test all avionics and electrical system and components.
Perform a continuity check on all wiring and cables.
Perform a Voltage Standing Wave Ratio (VSWR) check on all antennas, antenna cables and connectors.
Perform specific inspection/replacements as required.
Check oil cooler blower assembly and overrunning clutch for residual magnetism; replace as necessary.
Inspect oil cooler assembly for damage; replace as necessary.
If previous drive train items show magnetism, overhaul transmission.
If overrunning clutch assembly shows magnetism, remove engine and overrunning clutch and overhaul.
Perform a ground run operational check on the aircraft. Functionally check the flight control system, and all avionics, electrical, lighting, communication, and navigation systems.
Repair any damage and replace damaged components as required.
<b>If lightning strike is evident on main rotor system:</b>
Inspect blades for damage such as burns, pitting, skin separation, etc. If damage is evident, scrap damaged blade(s).
Remove hub assembly and return for overhaul.
Inspect all bearings in the fixed and rotating control system located on the main rotor mast.
Remove transmission assembly and overhaul.
Inspect main rotor mast and drive shaft for evidence of burns.
Check drive shafts for residual magnetism. If magnetized or damaged, scrap drive shafts and remove engine for overhaul.
<b>If lightning strike is evident on tail rotor system:</b>
Inspect blades for damage such as burns, pitting, skin separation, etc. If damage is evident, scrap damaged blade(s).

**Table 1. Conditional Inspections (Cont.)**

Requirement
Overhaul tail rotor assembly.
Scrap pitch change links and pitch change assembly.
Inspect bellcrank and control rod for any indications of arcing. Scrap parts with indications of arcing.
Overhaul tail rotor gearbox.
Inspect tail rotor drive shaft and drive shaft damper for magnetism and/or burns.
Check oil cooler blower assembly, overrunning clutch and tail rotor drive shaft couplings for residual magnetism; replace as necessary.
Inspect oil cooler assembly for damage; replace as necessary.
If previous drive train items show magnetism, overhaul transmission.
If overrunning clutch assembly shows magnetism, remove engine and overrunning clutch and overhaul.
Inspect engine mounts and fitting for damage. Replace as necessary.

# **Chapter**

# **08**

# **Leveling/Weight and Balance**



# TABLE OF CONTENTS

Para/Figure/Table	Title	Page
<b>08-00-00 Leveling</b>		<b>A</b>
<b>Maintenance Practices</b>		<b>201</b>
1. Helicopter Leveling		201
Figure 201. Leveling Helicopter		202
<b>08-10-00 Weight and Balance</b>		<b>A</b>
<b>For Basic Helicopter</b>		<b>201</b>
1. General Weight and Balance Information		201
A. Approved Center of Gravity Limits		201
B. Terminology		201
2. Helicopter Weighing		202
A. Helicopter Weighing Preparation		202
B. Preparation for Weighing – Electronic Method		202
C. Helicopter Weighing – Electronic Method		203
D. Preparation for Weighing – Mechanical Scales Method		203
E. Weighing Procedures – Mechanical Scales Method		204
F. Longitudinal CG Determination for Unadjusted Net Weight		204
G. Lateral CG Determination for Unadjusted Net Weight		204
H. Basic Weight and CG Determination		205
Figure 201. Balance Diagram		206
Figure 202. Weight and Balance Report Form (Sheet 1 of 2)		207
Figure 203. Surplus and Missing Items Report		209
Figure 204. Sample Basic Weight and Balance Record		210





# Section

**08-00-00**

**Leveling**



## LEVELING MAINTENANCE PRACTICES

### 1. Helicopter Leveling

(Ref. Figure 201) Leveling is accomplished by positioning helicopter to align a plumb bob with register marks on the target plate on cargo compartment floor.

---

Special Tools (Ref. Section 91-00-00)	
Item	Nomenclature
N/A	Plumb bob (commercially available)
N/A	Twine
N/A	Electronic weighing kit
N/A	Jack fittings
N/A	Hydraulic jack: 1-5 ton (900-4500 kg)

---

**NOTE:** Access to plumb line support bracket and target plate on floor of passenger/cargo compartment, requires removal of trim on right side of controls tunnel and floor carpet in aft compartment.

- (1). Suspend plumb line from bracket on right side of controls tunnel at Sta. 92.64, BL +6.20.
- (2). Adjust plumb line swing to level target plate on floor of passenger/cargo compartment.
- (3). With weight of helicopter supported by load cells of electronic weighing kit or jacks, as applicable, adjust appropriate jack until plumb line is centered with target plate.
  - (a). Adjust side jacks to level helicopter laterally.
  - (b). Adjust tailboom jack to level helicopter longitudinally.
  - (c). Recheck lateral and longitudinal levels until plumb bob exactly aligns with marks on target plate.
- (4). After leveling helicopter, remove plumb bob, reinstall trim and carpet, and close compartment door.

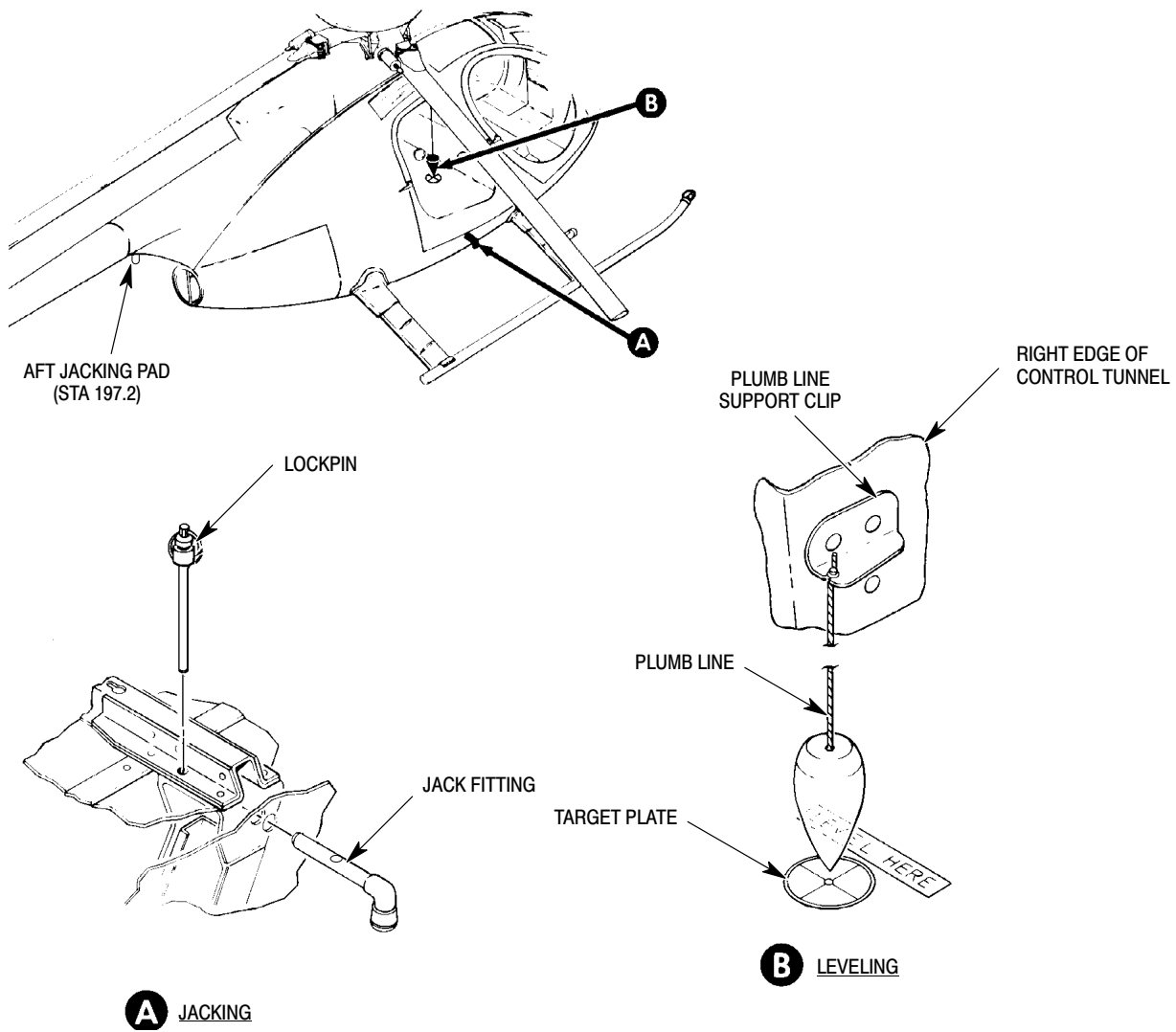

Figure 201. Leveling Helicopter

G08-0001

# **Section**

# **08-10-00**

# **Weight and Balance**



# WEIGHT AND BALANCE FOR BASIC HELICOPTER

## 1. General Weight and Balance Information

- (1). Removal or addition of fuel or equipment results in changes to weight and balance of a helicopter, and the permissible useful load is affected accordingly. These changes must be investigated to eliminate possible adverse affects on the helicopter's flight characteristics.
- (2). Basic weight and corresponding center of gravity is determined by weighing the helicopter without crew and payload; however, basic weight does include trapped and unusable fuel, full operating fluids, lubricants, etc., and installed equipment.
- (3). The longitudinal reference datum is located 100 inches forward of the main rotor centerline. The lateral reference datum is located along the longitudinal centerline of the helicopter. The vertical reference datum is located at a point 100 inches below the center of the main rotor blades (Ref. Figure 201 for balance diagram).

**NOTE:** Weight and balance information of optional equipment is in applicable Optional Equipment Manual.

Parameter	Wt lb/kg
369HM, 369HS (Serial No. 0001 thru 0100):	2400/1089
369HS, 369HE (Serial No. 0101 and subsequent):	2550/1157
369HM (Serial No. 0201 and subsequent):	2550/1157
Cargo Deck Capacity 950 pounds (Not to exceed 115 pounds per square foot)	

## A. Approved Center of Gravity Limits

(Ref. PFM)

## B. Terminology

The following are terms with definitions, used when determining helicopter weight and balance.

- (1). Arm: The distance in inches from the longitudinal (longitudinal arm) and lateral (lateral arm) reference datum of a part, to the center of gravity (CG) of the part.

**NOTE:** When viewing helicopter from rear, items to left of lateral reference datum (center line of helicopter) will be expressed as having negative (-) lateral arm, and those items to right of reference datum, a positive (+) lateral arm.

- (2). Center of gravity (CG): A point on a part where the part will be perfectly balanced. Center of gravity is measured in inches from a known reference. It can be determined using the following formula:

$$CG(in) = \frac{\text{Moment (in-lb)}}{\text{Weight (lb)}}$$

- (3). Moment: Product of weight of a part and its arm, either longitudinal or lateral, and is expressed in inch-pounds (in-lb).  
Longitudinal moment = weight x longitudinal arm; Lateral moment = weight x lateral arm.
- (4). Reaction point: A fixed point on helicopter where weight of helicopter counteracts on a weighing device. The main reaction points are at longitudinal Sta. 96.9, lateral Sta. ±25.6. The tail reaction point is at longitudinal Sta. 197.2, lateral Sta. 0.0.

## 2. Helicopter Weighing

Forms		
Nomenclature	Form No.	Figure No.
Weight and Balance Report	765B	202
Surplus and Missing Items	1702	203
Basic Weight and Balance Record	885	204

### CAUTION

- The controls access panel (aft side of Sta. 78.5 bulkhead) and two fuel cell access panels must be installed before jacking helicopter.
- There are two methods approved for weighing the helicopter. The preferred method is by using electronic weighing equipment. If equipment for electronic weighing is unavailable, the second approved method, mechanical scales, may be used (Ref. Weighing Procedures - Mechanical Scales Method).

### A. Helicopter Weighing Preparation

The following items are required and should be readily available prior to preparing and weighing the helicopter, using the electronic weighing method.

Special Tools
Jack fittings (two)

**NOTE:** Weigh helicopter without fuel if possible. If fuel is drained from low point in cell, 1.4 pounds of trapped fuel at 93.5 inch arm will remain. If fuel is pumped out using start pump, 3.7 pounds of trapped (unusable) fuel at 93.5 inch arm will remain. If defueling is not possible, ensure that fuel cell is full. Fluid weights are:

Fuel (JP-4)

6.50 pounds (2.95 kg) per U.S. gallon

Fuel (JP-5)

6.80 pounds (3.09 kg) per U.S. gallon

Lubricating Oil

7.70 pounds (3.50 kg) per U.S. gallon

- (1). De-fuel helicopter.
- (2). Select weighing area that is enclosed and draft-free, with hard-surfaced floor.
- (3). Ensure that helicopter and weighing area is cleared of all tools and debris.
- (4). Verify that rotor blades are uniformly spaced (90 degrees apart).
- (5). Check lubricant level at engine oil tank, main rotor gear box and tail rotor gear box sight gages. Add lubricant as necessary where less than full indication is noted.
- (6). Record weight, arm and moment of surplus equipment on board helicopter at time of weighing, which will not be part of basic helicopter weight (Ref. Figure 203).
- (7). Record weight, arm and moment of missing equipment, to be installed after weighing and prior to flight, that will become part of basic helicopter weight (Ref. Figure 203).
- (8). Install two fuselage jack fittings for main weighing points at longitudinal Sta. 96.9 and lateral Sta.  $\pm 25.6$ . Secure fittings with pip pins.

### B. Preparation for Weighing – Electronic Method

Special Tools
Electronic weighing kit
Hydraulic jacks (three)
Roll-away table, with weighing platform

- (1). Position hydraulic jack under each of main jacking points at Sta. 96.9, left and right sides of helicopter.
- (2). Attach electronic weighing kit load cell to each jack, and to weighing kit control unit.
- (3). Place third hydraulic jack on roll-away table with weighing platform. Attach load cell to jack, and to weighing kit control unit.



- (4). Position third hydraulic jack and attached load cell at aft jacking point of helicopter. (Longitudinal Sta. 197.2, lateral Sta. 0.0)
- (5). Turn electronic weighing kit power ON and allow warm up time as specified in electronic weighing kit operation manual.
- (6). Calibrate and zero-in each load cell prior to applying aircraft load (Ref. Electronic Weighing Kit operation manual).
- (7). Exercise load cells by jacking all three jacks simultaneously until load is supported by load cells at Sta. 96.9 and 197.2. Do not check helicopter level at this time.
- (8). Lower helicopter to floor so that no load is supported by load cells.
- (9). Repeat above steps (exercise load cells and lower helicopter) twice.
- (10). Recheck calibration and zero of each load cell.

- (a). Check lateral level by placing spirit level on main rotor mast, with axis of spirit level 90 degrees to longitudinal axis of helicopter. Adjust left or right jack at main jack points, as required, to center bubble in spirit level.
- (b). Place protractor or inclinometer on main rotor mast so that its axis is parallel to longitudinal axis of helicopter. Adjust jack at aft jacking point until protractor or inclinometer shows 3 degrees forward tilt.
- (3). Record reading shown on weighing kit control unit for each load cell (Ref. Example 1).
- (4). Lower helicopter to floor by bleeding off jacks, and clear load cells.
- (5). Record reading on control unit for each load cell under NO LOAD condition (Ref. Example 1). This reading represents calibration correction for each load cell. Depending on sign shown on control unit (+ or -), reading will have to be added to or subtracted from reading in step (3). above to obtain corrected weight for each cell (Ref. Example 1).
- (6). Add corrected readings for all three cells to determine total unadjusted net weight of helicopter (Ref. Example 1).

**C. Helicopter Weighing – Electronic Method**

Special Tools
Hydraulic jacks (three)
Spirit level
Protractor or inclinometer

When preparations have been made (Ref. Helicopter Weighing Preparation and Preparation for Weighing - Electronic Method), weigh helicopter as follows:

- (1). Operate three hydraulic jacks simultaneously until entire load is supported by load cells at Sta. 96.9 and 197.2.

**NOTE:** If conditions permit, helicopter may be leveled using plumb bob instead of spirit level.

- (2). After landing gear skids are clear of floor, level helicopter as follows:

**D. Preparation for Weighing – Mechanical Scales Method**

The following equipment and forms are required to weigh helicopter using mechanical scales.

Special Tools
Jack fittings (two)
Hydraulic jacks (three)
Roll-away table, with weighing platform
Beam platform scales (two), 1000 lb (450 kg) capacity with current calibration
Platform scale, 300 lb (135 kg) capacity with current calibration

When preparing to weigh helicopter using mechanical scales, complete preliminary

procedure (Ref. Helicopter Weighing Preparation), then perform the following:

- (1). Check 1000 pound (450 kg) capacity scales for zero.
- (2). Place 300 pound (135 kg) capacity scale on roll-away table with weighing platform, and check zero on scale.
- (3). Hoist helicopter so that main landing gear skids are sufficiently clear of floor to enable 1000 pound (450 kg) capacity beam platform scales to be rolled under main skids on left and right sides.
- (4). Roll 1000 pound (450 kg) capacity beam platform scales under main skids and position so main jack fittings at Sta. 96.9 are on centerline of scale.
- (5). Place jack on 300 pound (135 kg) capacity platform scale. Position roll-away table so that jack and 300 pound (135 kg) capacity scale are directly below aft jacking point at Sta. 197.2.
- (6). Lower helicopter so its weight is supported by scales.
- (7). Place jack on each 1000 pound (450 kg) capacity platform scale, inboard of main skids and directly below main jacking points at Sta. 96.9.
- (4). Simultaneously bleed off hydraulic jacks until helicopter skids contact 1000 pound platform scales, and total weight of helicopter is supported by scales and jack at Sta. 197.2.
- (5). Remove jacks from 1000 pound (450 kg) capacity platform scales.
- (6). Hoist helicopter until scales at right and left sides and jack at aft reaction point can be rolled clear of helicopter.
- (7). Lower helicopter to floor.
- (8). Weigh each jack on same scale jack occupied during helicopter weighing to get the tare weight. Record the tare weight at each reaction point (Ref. Example 1).
- (9). Subtract total tare weight for the three reaction points obtained in step (8) above from weight recorded in step (3) above to obtain total unadjusted net weight of helicopter (Ref. Example 1).

#### E. Weighing Procedures – Mechanical Scales Method

Once preparations have been completed, weigh helicopter as follows:

- (1). Operate jacks simultaneously until helicopter is supported only by jacks at right and left Sta. 96.9 and 197.2 reaction points.

**NOTE:** If conditions permit, helicopter may be leveled using plumb bob instead of spirit level.

- (2). With main skids clear of 1000 pound (450 kg) capacity platform scales, level helicopter.
- (3). Record weight shown on scale at each reaction point (Ref. Example 1).

#### F. Longitudinal CG Determination for Unadjusted Net Weight

- (1). Multiply net weight obtained at each jacking point by its longitudinal arm, to obtain a moment (Ref. Example 1).
- (2). Add three moments determined in step (1). to calculate total moment.
- (3). Divide total moment obtained in step (2). by total unadjusted net weight, to determine longitudinal CG.

#### G. Lateral CG Determination for Unadjusted Net Weight

**NOTE:** Lateral CG is not critical with normal internal loading. Certain optional equipment, such as an external cargo hook, may induce lateral CG outside lateral CG limits, if weight and CG control is not provided. However, the Initial Installation section for each optional equipment installation provides complete instructions on lateral CG control, to ensure operation within approved limits.

- (1). Multiply net weight for each jacking point by its lateral reaction point (left main, -25.6; right main, +25.6; and aft, zero) to obtain moment for each jacking point (Ref. Example 1).

- (2). Add three moments determined in step (1). above to calculate total moment.
- (3). Divide total moment by total unadjusted net weight to determine lateral CG.

#### H. Basic Weight and CG Determination

Using unadjusted net weight and longitudinal moment, determine basic weight and CG of helicopter (Ref. Example 2).

- (1). Add total weight and moment of missing equipment to unadjusted net weight and moment of helicopter.

- (2). Subtract total weight and moment of surplus equipment from weight and moment of helicopter determined in step (1). above.
- (3). Enter total basic weight, CG and moment in Basic Weight and Balance Record (Ref. Figure 204).

**NOTE:** Any changes that will affect basic weight and CG of helicopter must be recorded on Basic Weight and Balance Record (Ref. Figure 204), and revised basic weight and CG of helicopter must be calculated (Ref. PFM for preflight weight and balance requirements).

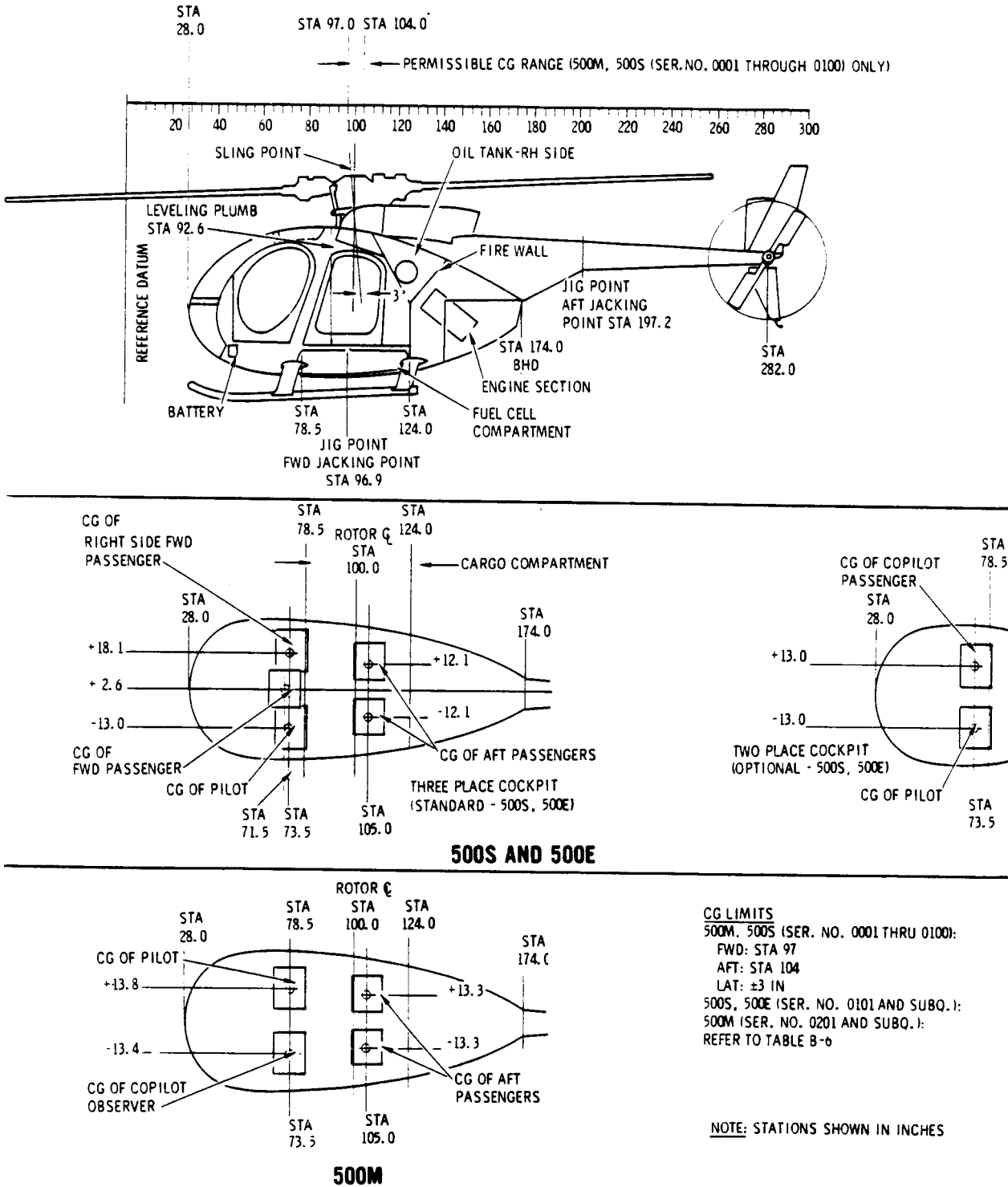

38-0006B

Figure 201. Balance Diagram

## WEIGHT AND BALANCE REPORT

### HUGHES MODEL \_\_\_\_\_

WEIGHED BY \_\_\_\_\_ CONFIGURATION \_\_\_\_\_

MODEL \_\_\_\_\_ SERIAL NO. \_\_\_\_\_ REGISTRATION NO. \_\_\_\_\_ DATE \_\_\_\_\_

WEIGHING POINTS	SCALE READING (LBS)	TARE OR CALIBRATION CORRECTION (LBS)	NET WEIGHT (LBS)	LONGI-TUDINAL ARM (INCHES)	LATERAL ARM (INCHES)	LONGI-TUDINAL MOMENT (INCH-LBS)	LATERAL MOMENT (INCH-LBS)
LEFT MAIN				96.9	-25.6		
RIGHT MAIN				96.9	+25.6		
TAIL				197.2	0.0		
TOTAL UNADJUSTED NET WEIGHT							
TOTAL WEIGHT OF SURPLUS EQUIPMENT (SEE TABLE 1)			-				
TOTAL WEIGHT OF MISSING EQUIPMENT (SEE TABLE 1)			+				
TOTAL BASIC WEIGHT							

REFER TO THE OWNER'S MANUAL FOR C.G. LIMITS APPLICABLE FOR GROSS WEIGHT RANGE.

SAMPLE

FUEL/OIL ABOARD AT TIME OF WEIGHING:

	EMPTY	FULL
FUEL	<input type="checkbox"/>	<input type="checkbox"/>
ENGINE OIL	<input type="checkbox"/>	<input type="checkbox"/>
MAIN GEAR BOX	<input type="checkbox"/>	<input type="checkbox"/>
TAIL GEAR BOX	<input type="checkbox"/>	<input type="checkbox"/>

**Figure 202. Weight and Balance Report Form (Sheet 1 of 2)**

MODEL \_\_\_\_\_ SERIAL NO. \_\_\_\_\_ REGISTRATION NO. \_\_\_\_\_ DATE \_\_\_\_\_

**EXAMPLES OF FORWARD, AFT AND LATERAL LOADING**

EXAMPLE 1, FORWARD	WEIGHT (LBS)	LONG. ARM (IN.)	LONG. MOMENT (IN.-LB.)
BASIC WEIGHT			
PILOT		73.5	
CRITICAL FUEL QUANTITY			
<b>GROSS WEIGHT (CRITICAL FUEL) – FWD C.G.</b>			

APPROVED FWD C.G. LIMIT FOR EXAMPLE 1 GROSS WEIGHT \_\_\_\_\_ INCHES.

EXAMPLE 2, AFT	WEIGHT (LBS)	LONG. ARM (IN.)	LONG. MOMENT (IN.-LB.)
BASIC WEIGHT			
PILOT		73.5	
<b>GROSS WEIGHT (ZERO FUEL) – AFT C.G.</b>			

APPROVED AFT C.G. LIMIT FOR EXAMPLE 2 GROSS WEIGHT \_\_\_\_\_ INCHES.

EXAMPLE 3, LATERAL	WEIGHT (LBS)	LATRL. ARM (IN.)	LATRL. MOMENT (IN.-LB.)
BASIC WEIGHT			
PILOT			
<b>GROSS WEIGHT (ZERO FUEL) – LATERAL C.G.</b>			

APPROVED LATERAL C.G. FOR EXAMPLE 3 GROSS WEIGHT \_\_\_\_\_ INCHES.

\*SEE FLIGHT MANUAL, SECTION 6, FOR C.G. LIMITS AT GROSS WEIGHT.

Page 2 of \_\_\_\_\_

G08-1004-2

**Figure 202. Weight and Balance Report Form (Sheet 2 of 2)**



AIRCRAFT MODEL		SERIAL NUMBER		CONTINUOUS HISTORY OF CHANGES IN STRUCTURE OR EQUIPMENT AFFECTING WEIGHT AND BALANCE										PAGE	
DATE		ITEM NO.		DESCRIPTION OF ARTICLE OR MODIFICATION		WEIGHT CHANGE					RUNNING TOTAL BASIC AIRCRAFT				
		IN OUT				ADDED (+)		REMOVED (-)			WEIGHT		LONG ARM		
						WEIGHT	LONG ARM	MOMENT IN LB	WEIGHT	LONG ARM	MOMENT IN LB	WEIGHT	LONG ARM	MOMENT IN LB	
					Basic Weight - Delivery						1510.0	109.0	164561		
SAMPLE															
ENTER CONSTANT USED BELOW LINE															

McDonnell Douglas  
Helicopter Company

G08-1006

Figure 204. Sample Basic Weight and Balance Record



EXAMPLE 1

Determining basic weight and longitudinal CG - 369H

Weighing Points	Scale Reading (lbs)	Tare or Calibration Correction (lbs)	Net Weight (lbs)	Arm (in.)	Moment (in.-lb)
Left Main	498.6	-1.5	497.1	96.9	46149
Right Main	500.7	+ 0.5	501.2	96.9	48566
Tail	154.7	0.0	154.7	197.2	30497
Total Unadjusted Net Weight			1153.0	110.3	125212

EXAMPLE 2

Determining basic weight and longitudinal CG - 369H

Weighing Points	Scale Reading (lbs)	Tare or Calibration Correction (lbs)	Net Weight (lbs)	Arm (in.)	Moment (in.-lb)
Left Main	498.6	-1.5	497.1	96.9	46149
Right Main	500.7	+ 0.5	501.2	96.9	48566
Tail	154.7	0.0	154.7	197.2	30497
Total Unadjusted Net Weight			1153.0	110.3	125212
Total Weight of Missing Equipment (Ref. Fig. 203)			+21.0	93.6	+1966
Total Weight of Surplus Equipment (Ref. Fig. 203)			-1.3	96.9	-126
Total Basic Weight			1172.7	110.1	127052

